

First published in 1949, Felix is released weekly during term time and is distributed around Imperial's London campuses. All students, staff, and alumni are welcome to contribute to the paper.



**Felix takes aim at the 2024 Presidential election** → READ MORE ON PAGE 15

# Minimum wage increases and a vape tax



# Labour's new budget and what it means for you

**READ MORE ON 4**

**NEWS**

**Imperial opens first US Hub in San Francisco**

→ READ MORE ON 6

**ARTS & CULTURE**

**Hail to the Prints: a foray into election posters**

→ READ MORE ON 9

**FOOD & TRAVEL**

**A look at the newest food outlet on campus: La Cantina**

→ READ MORE ON 14

**CATNIP**

**Feb Senton for President!**

→ READ MORE ON 21

**SOCIETIES**

**What's on this week!**

→ READ MORE ON 23

**Want to know what's going on around campus?**

**Sign up to our newsletter by scanning the QR code below:**



- felix\_imperial
- felix@ic.ac.uk
- felixonline.co.uk

# DECLARATION

At *Felix*, we believe that it is always in the interest of the students to be in the know. Transparency in the workings of the College and the work of your student representatives is key. Therefore we, the *Felix* Editors, on behalf of the team promise that:

**We will, to the best of our ability, tell you the whole truth and nothing but the truth.**

**We will keep your confidence and will only publish something you say to us if you have explicitly said that we can.**

**We will work to expose unfairness and discrimination in all forms that it takes at the College.**

**We will treat fairly any article sent to us, regardless of point of view, and do our best to work with you to prepare it for publication.**

Signed by:  
**MOHAMMAD MAJLISI**  
Editor-in-Chief

## Copyeditors

**NIKESH CHARVALA**  
**SOPHIA LAUREN MAMON**  
**ANYA AGARWAL**

# The Felix Team:



**MOHAMMAD MAJLISI**  
Editor-in-Chief,  
News Editor



**TAYLOR POMFRET**  
Deputy Editor-in-Chief,  
Sports Editor



**CHARLOTTE PROBSTEL**  
Chair,  
Societies Editor



**TARUN NAIR**  
Chief Copyeditor  
Film & TV Editor



**RUBY LYDFORD**  
Publicity Officer,  
Catnip Editor



**ELIF CIVELEKOĞLU**  
Social Secretary,  
Arts & Culture Editor



**IVIN JOSE**  
Treasurer  
Puzzles Editor



**OSCAR MITCHAM**  
Environment Editor



**GUILLAUME FELIX**  
Comments Editor



**ADITI MEHTA**  
Books Editor



**ALIA FRIEDMAN**  
Business Editor



**GILBERT JACKSON**  
Arts Editor Emeritus



**ROLANDO CHARLES**  
Photography Editor



**EMIRI HOSOKAWA**  
Senior Webmaster



**ELSON THO**  
Junior Webmaster



**AMBER DUNMORE**  
Science Editor



**WALT GAO**  
Head Photographer



**AND OUR NUMEROUS  
CONTRIBUTORS ...**

Located at Beit Quad,  
Prince Consort Road  
London, SW7 2BB

Printed by Iliffe Media  
Winship Road,  
Milton, Cambridge  
CB24 6PP

Registered Newspaper  
ISSN 1040-0711  
Copyright © 2024 *Felix*

## Advertising

MEDIA	SIZE	PRICE (£)
Print	Quarter-Page	25
	Half-Page	30
	Full-Page	45

## Contact us

News ..... felix@ic.ac.uk  
Books ..... books.felix@ic.ac.uk  
Film&Tv ..... film.felix@ic.ac.uk  
Catnip ..... catnip.felix@ic.ac.uk  
Comment ..... comment.felix@ic.ac.uk  
Puzzle ..... puzzle.felix@ic.ac.uk  
Food&Travel ..... food.felix@ic.ac.uk  
Sport&Society ..... sport.felix@ic.ac.uk  
Environment ..... environment.felix@ic.ac.uk  
Science ..... science.felix@ic.ac.uk

## EDITORIAL

---

# A reflection on Black History Month



**Rolando Charles**  
Photography Editor

I spent this past weekend in Paris with a few friends. As is expected of tourists, we visited a few museums (d'Orsay, de l'Orangerie, Louvre) and I was intrigued by the other visitors and the artwork on display. It is not unusual to see the exhibitions dominated by the white artists that embody Western art and culture, as these museums represent Europe, and are a product of the colonialist wealth these countries were built on. More importantly, very few of my fellow visitors were members of the Black community. A rough estimate based on the Louvre visitors demographic in 2022, yields that, of the 7.8 million visitors that year, about 300 – 700 thousand were Black. Not even one in eight at most.

Surrounded by the opulence of these buildings, I found myself grateful to have the opportunity to visit these museums and see these famous works of art. And in light of the numbers above, I'm reminded that free access to this cultural and artistic treasury is a privilege that the Black community has long been denied.

It is in this spirit of recuperation and equality, right at the end of this year's Black History Month, that I'd like to encourage the reader to think of their inherent representative role within their family, their peers, and their communities. Studying here and working for oneself, for one's family and friends, provides the opportunity to inspire others and claim the education, and the artistic and scientific liberation we are owed.

Over time, my father has shown me that the racism we experience, the injustices and violence we have endured for generations, cannot and should not hold up

to the will to live a better, fairer life. If today I have the opportunity to study at Imperial College it is because of his and my family's sacrifices. In this extremely privileged position, I in turn will do my absolute best to inspire more Black people to take the positions, the roles, and the jobs they deserve and have been forced to give up because of the consequences of bigoted and inhuman ideals, and horrendous economic exploitation.

As I metaphorically walk through centuries of art and science, I am still saddened not to see enough Black academics, engineers, doctors, artists, and political representatives around us. I encourage you, the reader, to recognise the newly acquired power you hold over your own future and our community.

---

## Letter to the Editor

Dear Felix,

It is surprising the limited treatment UK student finance actually receives relative to its obvious importance. Seldom does the subject appear to merit explicit discussion except as a means toward the furtherance of polemics, a case in point being your recent editorial in *Felix* #1855. Contextually, the plethora of coverage as well as ongoing mainstream media focus – including quality newspaper commentary – tends to frame the UK student loan system in similar terms; redolent of high indebtedness, mounting interest and, by implication, something which is somehow unfair and unsportsmanlike. However, as the Nobel Laureate Richard Feynman pointed out many moons prior, “The first principle is that you must not fool yourself – and you are the easiest person to deceive.” For one thing, the student loan, though most probably equated to in many people's minds, differs significantly from its US equivalent; it is neither predatory, nor exploitative, much less perennial because it is income-contingent. Graduates therefore have to earn, depending on the plan they are on, somewhere in the mid £20,000 range before triggering repayment, this means relatively few will be contributing much in their early years of employment. Those that do earn above the average salary will likely contribute a relatively modest amount with only the truly high earners (17% according to a 2023 IFS study) paying anything proportionate to the cost of the loan provided. Furthermore, the

‘loan’ itself lapses after 30 (recently increased to 40) years. Because of these considerations a recent article in the *Times Higher Education* by this author (16th Sept 2024) emphasises a better way to conceive of UK HE student finance is to view it as a tax rather than loan. Martin Lewis, the well-known financial journalist, has been arguing along similar lines on his MoneySavingExpert platform for many years now in an attempt to demystify the financial commitment and costs involved. In the wake of this, the question that really needs to be addressed is whether a student should contemplate attempting to pay back the loan in full, to which the answer is it's complicated and depends on one's earnings as well as the plan involved (although the YouTube channel Damien Talks Money gives an excellent and up-to-date summary of how to approach an answer without lapsing into hard core financial advice).

The deterrent effect of language in student finance not only skews its mainstream conceptualisation prejudicing the discussion thereafter, it also comes with another very unfortunate recently highlighted side effect (identified by the 2022 Muslim Census Survey which echoes previous findings from Challender & Mason's 2017 peer reviewed article); it inadvertently discourages potential students from debt-averse backgrounds – comprising working and middle class British people who are not financial savvy as well as many practicing Muslims who refuse to deal with loans that incur interest which they believe is pro-

hibited to them. In the latter case, this amounts to around 120,000 potential undergraduates over the past 10 years, including 6,000 per year who avoid university education altogether, together with another 6,000 per year who refuse the maintenance loan exposing them to considerable hardship thereafter. Admittedly, it appears the majority of suitably trained Muslim jurists conversant with UK student finance (the British Board of Scholars & Imams, British Fatwa Council etc and, somewhat ironically, the US based scholar and academic Yasir Qadhi being good examples) reject the notion it is synonymous with the term *riba* or “economic exploitation” (usually equated to “usury”) which is explicitly repudiated in the Qur'an; however, such awareness has clearly not reached everyone in the community and doing so will be challenging in the face of prevailing orthodoxy and programming absent significant effort otherwise. One way to address the situation would be for universities to change the information provided to prospective students from their present offerings which mostly echo the loan-cum-debt presentation of student finance on institutional webpages, for example. Despite the obvious attraction of potentially recruiting more students into the university system, many from a widening participation background, how challenging do readers think this task is given the orthodoxy and programming prevalent in the UK HE sector?

## NEWS

# Reeves reveals budget, but what does it mean for you?

## Labour's first budget in 14 years fails to mention higher education institutions

**News Writer**  
SALEENA LIVERA

**News Writer**  
ISA DUCHOVNY

**Editor-in-Chief**  
MOHAMMAD MAJLISI

Labour's first budget has not included any proposed changes or funding for higher education institutes, despite experts in the sector calling for a change to the current student loan system, and increased funding as universities across England's finances tighten. Students' can expect increases in the minimum wage, and a possible rise in bus fares.

This budget, monumental in being the first one delivered by Labour in 14 years and the first delivered by a female chancellor.

The Chancellor of the Exchequer Rachel Reeves has placed a strong emphasis on restoring economic stability. Reeves has accused the Conservative Party of leaving the country with "broken" public services; but has strikingly failed to mention any specific financial plans for universities.

### Minimum wage increase

Reeves has announced that the minimum wages will rise this year, with the minimum for 18-20 year olds increasing by 16% to £10 an hour. Moreover, the chancellor has gone beyond the guidance of the Low Pay Commission in increasing National Living Wages by 6.7%. This entails a £12.21 an hour minimum for all workers aged 21 and over from April 2025. In addition, it has been asserted that a single adult rate will be gradually implemented, meaning that pay will become equal

for all over-18s during this government. With inflation rates predicted to fall to 2.0%, this budget can be seen as primarily an attempt to battle the cost of living crisis. Students have faced the brunt of the cost of living crisis, with a survey by the Higher Education Policy Institute finding a record 56% of UK undergraduates work part time; three quarters of them did so in order to meet living costs.

### National Insurance rises

The chancellor confirmed a 1.2% increase in employer National Insurance (NI), taking the total to 15%, which places additional costs on UK universities for staff pay. A 1% rise in NI contributions would collectively cost higher education institutions approximately £130 million. This announcement comes during a funding crisis in the higher education sector, and may result in further cuts and redundancies. This follows a call from universities to raise fees for students by £3,000 a year due to inflation.

Students faced disruption to their degrees following strikes by the University and College Union in 2022 and 2023. Following negotiations in 2024, the Joint Trade Union (JTU), which represents the three trade unions operating at Imperial, agreed to a minimum 4% wage increase in May this year.

Business leaders have indicated that recruitment numbers may go down in the short term as their NI contributions increase. This may indicate some issues with graduate jobs, with graduate recruitment slowing post-COVID and Stephen Isherwood, chief executive of the Institute of Student Employers (ISE), warning that demands for jobs were already at "record-high" levels. "The graduate jobs market is tough. There are a lot of students chasing a small number of vacancies," Isherwood said, following a recent report by the ISE (see *Felix* #1855).

Taxes are now at a record high, although reporting

by the *Financial Times* indicates this is the norm across Western countries, due to high inflation and poor economic prospects post-COVID.

### Beer, vapes, and other vices

Additionally, the chancellor pledged "a penny off the pints at the pubs," by cutting duty on draught alcohol. Duty rates on non-draught alcohol will increase according to RPI next February. A new flat rate tax on vaping has been introduced, starting in October 2026 as well as announcing an increase in tobacco duty "to maintain the incentive to give up smoking." This follows a ban on disposable vapes set to be enforced from June 2025.

### A commitment to research

Beginning her speech by committing to "invest, invest, invest", Reeves has pledged to invest £6.1 billion in research and development. In particular, she has vowed to fund sectors in science such as engineering, biotechnology, and medical sciences.

This follows a speech at the 2024 Labour Party Conference where the Secretary of State for Science, Innovation, and Technology expressed that science and technology are "the most sustainable route to wealth creation, opportunity generation, secure employment and economic growth".

### Transport fare hikes

The bus fare cap has been increased from £2 to £3. Whilst it is unclear if this will affect London, Mayor of London Sadiq Khan has confirmed a 4.6% increase in Tube prices in accordance with the fare hike in National Rail.

# OT Interviews: Emina Hogas, Deputy President (Education)

**Felix interviews Emina on her campaign promises and the experiences of postgrad students at Imperial**

**Editor-in-Chief**

**MOHAMMAD MAJLISI**

**D**eputy President for Education (DPE) Emina Hogas always looks impressive. Always dressed formally, typically in a shirt or blouse, she tells me it's because she has many meetings to go to. Professionalism is key, when she is the point of contact between the College and the Union for academic policies.

Emina has the most College meetings of all the Officer Trustees. She explains how "there's a skill" to attending meetings. "I try to prepare for them as much as possible and make full use of my time in those meetings. Ultimately, I'm very privileged to be part of those rooms and I want to make the most of them while I am in them. It's not so much the meetings but the prep that has to go into them which is considered business as usual so that's completely outside of my own objectives [her manifesto promises] which can be quite difficult.

"I think it was definitely a hard thing to get to grips with in my first month working especially because

cause I was juggling my [Master's] thesis at the same time, but I think I've gotten a better handle on it now. Slowly, I'm learning how to also incorporate my objectives into these meetings and make full use of them, both on the input that the College wants from students and what I'm trying to push for."

Voted in on an impressive mandate of 87%, despite being the sole candidate, plays into Emina's dedication to the role. "I'm doing everything in my power to show that if there was somebody else running, I would have in fact done my hardest to work for this role because I deeply care about making a change and improving the Imperial student experience in the long run."

Previously working several roles in the BioSoc committee, and a course representative during her masters, Emina decided to run as a sabbatical officer due to a "lack of parity and consistency of experience". She explained how she "didn't think" the disparity in course quality was "fair, especially now with the increase in student prices for internationals and the upcoming discussions about increase for home students". I wondered if the disparity was due to changing departments or due to the type of student she was, after transitioning from an undergrad to a taught postgraduate. Emina said, "I don't have proper insight on what it is to be a postgrad at Imperial because I had the luxury of being here for my undergrad so I was still well connected with the Union, previous friends that were doing their integrated Masters so I still had a community to return to," but seeing how new starters at Imperial struggled to "expand[ing] too much outside of the initial group of friends that they met in the initial week just be-

cause they didn't have time to.

"My course specifically was very Autumn Term-heavy and I think that really hindered how people made connections early on and especially for a year that really just overwhelms you. You don't really have much capacity outside of doing the work, getting the deadlines and all of that so personally I think it depends a lot on from taught course but I think overall taught courses can be quite intensive for new students at the university and some can find it difficult to actually take advantage of all the services [available].

"My experience as a post-grad is definitely what made



**I'm very privileged to be part of those rooms and I want to make the most of them**

me go for the role and I think it's given me a special type of insight into the difficulties that post-grads face despite possibly not having gone through all of them myself but being quite close to those who have."

One of Imperial College Union's core aims this year is communication, especially towards research postgrads, a demographic that historically hasn't engaged with the Union. Emina elaborated on how she is the point of contact for Academic Representatives, which are members of the IC Unions representation team, "So yeah, we're taking out time to have drop-ins, we have blocked out time as a team to update each other on our objectives and how we can delegate tasks or just distribute things amongst us."

Emina's aims as DPE are to centralise mitigating circumstances, improve academic feedback, help international students integrate into College life, and form an alumni network for "unconventional careers".

She has started with mitigating circumstances (mit-circ) because she feels "everything is intertwined realistically, especially mit-circ and assessment and feed-

back,” and “assessment and feedback has been kind of plan B just for the time being is because, realistically, I need to wait for the reps to take on the roles, otherwise I can’t really feedback from all ends of the College about what’s actually needing attention.”

Her aim is to introduce “a mitigating circumstances policy that would allow evidence-free extensions. It’s based off something that other universities are doing where essentially, we’re giving back students some autonomy around deadlines especially for courses that have a lot of assessments. It would be capped at three a year”, to prevent misuse without being an issue. “Staff have had things to say but I think we’re on the path of seeing something like this hopefully taken on by the end of the year. And in terms of unifying mit-circs, that’s very difficult just with the IT side that the university uses. It’s not so much a policy thing, more of a what can actually be implemented with the systems that we have. That means that we have to wait a little bit longer but what we’re doing now is to try and create policies so that that can inform the tech.”

I wonder what an unconventional career path is. To Emina, it’s all the jobs you dream of doing, “I think the first example that comes to mind is a physicist who then decided to be an orchestra conductor. He did a full MSci and now just conducts orchestras.” She continues, “it’s something that you wouldn’t possibly think of going into in your first year.” I ask if journalism is also considered. “It’s just broadening those horizons as early as possible,” Emina continues after I ask about why it was a manifesto promise. “I obviously see what’s happening in the job market and I think we’re not seeing that many people actually happy with their jobs nowadays. I think that comes from people having to choose their careers at the age of 16 and thinking that they are locked into that all the way and I don’t think that’s fair. It came from wanting to give people the opportunity to fully explore themselves which is what university is for it’s not to just hammer away at work and like narrow yourself down into a specific stream.”

# College launches Imperial Global USA in San Francisco

## New Innovation Hub to “support science and tech partnerships” is Imperial’s first UK-US venture

**Editor-in-Chief**  
**MOHAMMAD MAJLISI**

Imperial College’s first physical presence in the US launched on Wednesday 30<sup>th</sup> October in San Francisco. The US hub will “support new science and technology partnerships” as part of Imperial’s core strategy goal of Convergent Science.

The aim of the US Hub is to foster relations between “innovators partnering on both sides of the Atlantic” in order to target global challenges.

Imperial Global USA will be led by an External Advisory Board, chaired by alum Wendy Tan White, who is now CEO of software and AI robotics company Intrinsic.

Imperial aims for 100 new science and technology partnerships by 2025 through the Global USA hub.

Professor Hugh Brady, President of Imperial College London said: “Opening a physical presence in San Francisco is going to supercharge our capabilities to support world-leading British science and tech to collaborate with American partners. Our new hub will be a front door in the heart of the Bay Area to help spin-outs, academics and innovators create the kind of partnerships that will lead to world-changing scientific discoveries.”

The news follows the Labour government’s first budget, where it announced a commitment to funding research and development in order to boost the economy and growth. Peter Kyle, UK Science and Tech Secretary said: “Imperial is the first UK university to set up a science and tech base in the US and its new hub in San Francisco represents a hugely exciting opportunity to bring together the

great minds of UK and US research in driving forward discoveries that benefit both our nations and beyond.

“By building on existing successful partnerships, like advancing AI in healthcare and scaling up clean energy solutions, this hub can play a key part in accelerating new technologies that will fuel economic growth and deliver real-world solutions to global challenges for years to come.”

The opening of the USA hub follows the development of the WestTech Corridor, based around the existing campuses in London, as part of the current strategy Science for Humanity. Last year the College launched the Pears Cumbria School of Medicine in partnership with the University of Cumbria. The Global USA hub is the second of four regional hubs, with the first opening in Singapore earlier this year.



Left: President Hugh Brady speaking at the Imperial Global USA Launch. Right: Wendy Tan White (left) and Vice-Provost Professor Mary Ryan (right) at the launch. Imperial College London

## SCIENCE

# ICLR celebrate EuRoC success

## Felix sits down with ICLR members Andrei Paduraru, Soham More and Pablo Duhamel to discuss the trials and triumphs of launching Nimbus 24

Science Editor  
**AMBER DUNMORE**

**N**imbus 24, Imperial College Rocketry Team's (ICLR) latest creation, was a symbol of both prophetic irony and the prevailing power of aspiration and hard work. The rocket, named after dark rain-bearing cloud, faced its fair share of weather-related obstacles at this year's European Rocketry Challenge (EuRoC).

Created in 2020 by the Portuguese Space Agency, the competition brought together 25 teams from some of Europe's top technical universities to compete in rocket launching. ICLR entered with their fully student-developed, 3km liquid bi-propellant rocket, Nimbus 24. This was ICLR's fourth time attending the competition, and their first launch with their new engine, THANOS-R.

"Throughout the year we have done loads of testing. Last year we did something like 20 static fires, all at our Silwood campus."

The team achieved flight readiness on 11th October, the first day scheduled for launches of the competition. At 4:57pm, Nimbus 24's Thanos-R engine ignited for the 20th time this year and the rocket soared to 2.6km altitude, making ICLR the closest team to the 3km target of the category across the entire competition.

Despite initially being told by officials to abandon all hopes of launching due to poor weather conditions, as if scripted by fate, an opening in the sky provided them with the perfect window to launch.

Andrei reflects on this moment: "Our team, when they saw the rocket launch, screamed so loud that we got given

Science Editor  
**TAYLOR POMFRET**

a safety penalty. It was our first fully student developed rocket, and everyone was really happy. We can't really blame EuRoC - rules are rules".

The team entered the competition with a fully student-developed, 3km liquid bi-propellant rocket. Nimbus 24 featured an aluminum airframe with mass-optimised aluminum alloy structures, composite bodywork, a 3U deployable payload and the highest thrust student rocket engine seen in the UK. Weighing in at 55kg dry and measuring 4.5m long, the top speed of Nimbus during the launch was 257 m/s (963 kph), attaining a maximum acceleration of 7.8g.

ICLR came second in three categories in the competition: payload, team, and flight award. The team award has been a challenge for ICLR in previous competitions, but this year they made significant progress, amassing a total of 191 out of 200 points. The team claim

they would've potentially even won the flight award, if it wasn't for their aforementioned safety penalty picked up for celebrating their launch.

Members of the team expressed their thanks to the Aeronautics department, Mechanical Engineering department and



**When we saw the rocket launch, we screamed so loud that we even got a safety penalty!**

technical supervisor Dr Aaron Knoll.

"None of this would be possible without them. We are, as of today, the only team in the UK that has its own test site (Silwood Park). We thank the Aero and Mechanical engineering departments for granting us this space. We'd also like

to thank Dr. Aaron Knoll; he ensures we abide by the college rules while being a massive supporter of what we do."

Following their success at EuRoC 24, the team set their ambitions to two main projects. The first is to build and test a new bi-propellant rocket, in preparation for next year's competition, and the second is to build a self-landing rocket using thrust gimbling, much like SpaceX.

Reflecting upon their time in ICLR, launch team member Soham gave the following advice for those with ambitions of getting involved with rocketry.

"Show up and show an interest - I see this as a push and pull kind of thing - you know you only get out as much as you put in. We're happy to teach and mentor anyone and accommodate people proposing their own projects too.

When I first came to Imperial, I didn't know anything about rocketry, I wasn't particularly interested in space or rockets - I just wanted to do something cool for the year. I showed up to the first meeting and I got placed in the airframe team, and just slowly spending time in the scene really helps build your passion for rocketry."

Pablo adds, "This experience over the past 4 years of doing rocketry will definitely help me when I start applying for jobs, the first thing I want to talk about in interviews is what I did for rocketry, probably not anything I did during my labs."

On behalf of Felix, we'd like to congratulate the team on their successful launch of Nimbus 24 and wish them all the very best for their future rocketry endeavours.



ICLR team carrying their rocket, Nimbus 24, to the launch pad. ICLR

## ENVIRONMENT

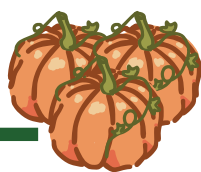

# UNEP, WMO, and CCC call for action, but is anything different?

Environment Editor  
**OSCAR MITCHAM**

**A**head of each Climate Conference of the Parties (COP), a slew of reports are released seeking to inform the proceedings. For example, the United Nations Environment Programme recently released their Emissions Gap Report 2024. Emissions Gap Reports are published ahead of each COP and assess the gap between pledged greenhouse gas emissions reductions and the limits to keep warming to, in this case, 2.0, 1.8, and 1.5 degrees. Grantham Institute Research Director Professor Joeri Rogelj was a lead

author on the report and Dr Robin Lamboll was among its contributing authors. This report, the fifteenth released, calls for "a quantum leap in ambition" on Nationally Determined Contributions (NDCs), which are non-binding emissions targets set by each country. NDCs are submitted every five years starting in 2020 but can be updated at any time. This cycle lines up with the global stocktake which is intended at informing the next round of climate action plans. The first-ever stocktake concluded earlier this year. The new round NDCs should be submitted well in advance of COP30, so we expect some nations to do so before COP29.

57.1 GtCO<sub>2</sub>e last year. UNEP reports a massive 24 GtCO<sub>2</sub>e gap between our annual emissions in 2030 including current policies and their 1.5-compatible emissions pathway. This gap falls to 19 GtCO<sub>2</sub>e when including all NDCs. Net zero targets, it seems, could make a big difference. Assuming all NDCs and net zero targets are met, the world may keep to 2 degrees, but unfortunately policy is so far behind meeting net zero targets: it is as if there aren't even concepts of a plan, with a 36 Gt gap for 2.0 degrees and a 48 Gt gap for 1.5.

The Climate Change Committee in the UK has also weighed in on our NDCs. They recommend the UK's NDC to commit to reduce territorial emissions by

clones, and tipping points (as well as damages to human health and ecosystems - all of which are significant), a 2024 paper in Nature found that the world is most likely already committed to a permanent income reduction of 19% worldwide by 2049; the impacts are worse in South Asia and Africa with an approximately 22% income reduction. Globally, this is a cost of roughly \$38 trillion /year in 2005 international dollars (£49 trillion /year). The cost of mitigation in line with 2.0 degrees (\$6 trillion /year) is roughly six times lower than the damages.

The state of finance for adaptation is even worse. Adaptation is just not sexy enough, with less clear short-term incen-

centrations of long-lived greenhouse gases after any natural effects and brings the unsurprising news that GHG concentrations continue to rapidly increase and have hit record highs.

The Climate COP, for which COP29 will be in November, sits alongside two other conventions: the Biodiversity COP and the Desertification COP. Both aim to meet every two years. The Biodiversity COP16 finishes today in Colombia and Desertification COP16 will take place in Saudi Arabia in December.

If this feels like a lot of work for a little progress, you're right. But it's important to frame this in the context of the role of the UN. The United Nations Framework Con-



Covers of Emissions Gap Reports from 2017 - 2024. UNEP

vention on Climate Change was a fantastic achievement for last century, but as Paul Dickinson put it, the UN is not meant to get you to heaven, but to stop you going to hell. With the beyond catastrophic warming scenarios of 4+ degrees now much less likely, there has been some success.

The reality is that the people have the power. Collective, grassroots, community-led action has an incredible potential to drive us beyond what's easy to the justice we really need. Climate action is a story of opportunity and hope and that's a story we've got to tell.

81% by 2035 compared to 1990 levels. We've already achieved a roughly 50% reduction since 1990 and our current 2030 NDC puts us almost in line with 1.5 degree modelled domestic pathways. Taking into account the UK's fair share of emissions paints a more worrying picture with a requirement for much faster reductions ideally to net negative emissions by 2030 and much more climate finance, according to Climate Action Tracker. This is no surprise given the UK's historical emissions.

Climate finance is such a no-brainer, it would be funny how little action we're taking if the upcoming devastation weren't so frightening. Ignoring the impacts of heatwaves, sea level rise, tropical cy-

cles, and tipping points (as well as damages to human health and ecosystems - all of which are significant), a 2024 paper in Nature found that the world is most likely already committed to a permanent income reduction of 19% worldwide by 2049; the impacts are worse in South Asia and Africa with an approximately 22% income reduction. Globally, this is a cost of roughly \$38 trillion /year in 2005 international dollars (£49 trillion /year). The cost of mitigation in line with 2.0 degrees (\$6 trillion /year) is roughly six times lower than the damages.

Another report, the World Meteorological Organisation's Greenhouse Gas Bulletin No. 20 was published on Tuesday, again with a view to inform COP29. The annual publication analyses global

tives for private finance. This is further complicated by adaptation plans being extremely local, despite this usually being a benefit. This leaves most of our attention on mitigation, even though adaptation pays back four times in risk and GDP degradation avoided (\$1.7 trillion of investment producing \$7.1 trillion total benefits across five key target areas). By 2030, UNEP estimates there will be a \$140-300 billion annual adaptation demand which is far larger than current investment.



## CULTURE

# Hail to the prints!

## An election season special looking at campaign posters through the years

Arts Editor Emeritus  
**GILBERT JACKSON**

One may ask, “What has art got to do with voting for the lesser of two evils?” Yet, there is a spoken half-truth in the Arts section that it usually has everything to do with everything. Elections are not simply about displays of hard power such as seen in manifestos, debates, and the occasional caucus, but also displays of soft power: campaign adverts, jingles, slogans, and artful posters. Election posters, or the occasional cartoon, have been pivotal in displaying candidates to the general populace. In the time of Washington and Adams, most of the public would not have even been able to put a candidate’s name to a face, or generally have been able to read for what they stand for at all. A poster, however, with subtle (or in America’s case, not so subtle) imagery can effectively convey a message more clearly to the less literate than any promotional pamphlet could ever hope to achieve. Therefore, this article displays and eloquently walks through a selection of promotional material candidates have stuck on the local community walls over the years. In true Arts section style, we are bound to candour.

### William Henry Harrison

William Henry Harrison was, by any mark, the shortest-lived president in US history, dying exactly one month after taking the oath. However, his poster speaks volumes, long outliving the man. Firstly, it is evident to see that he is a man of high military stature: as the last President elect to have initially been a British subject, his poster reflects the “American Triumph”, although now it looks more like he is about to lead a fateful crossing of the Alps. What the observant viewer may also notice is the bundle of military items at the bottom of the poster, reminiscent of the fasces: a symbol of unity and community at the time, although it became defunct after the 1930s due to connotations with fascist imagery. It is very clear what Harrison would have done as President if his immune system was not tired of battling pneumonia: continue to promote

freedom to all the “American way” – with large scale military conquest.

### Abraham Lincoln

One theme one can notice with a lot of presidential campaign posters is the dual portrait of both president and vice-presidential hopefuls. While it may seem obvious nowadays, it is important to know that a frequent number of presidents before had been military men who had fought for the States. Their career had been solidified quite easily and the art required to promote them (full military dress, heroic posing) was fairly easy to capture. In the case of lawyer and desk jockey Abraham Lincoln, capturing his patriotic tendencies was trickier. Instead, his campaign poster attempts to speak to another American ideal: equality before God. Both the president and vice-president are on a level footing with each other, offering the idea that both men are equals. This is consolidated with details of both a book of the law, and the book of God, cementing the idea that these men intend to abide, represent, and solidify the law of both the human and the divine.

### Eugene V. Debs

People oftentimes forget that before 1919, America did in fact have a socialist party. This poster retains the classic dual portrait that many candidates had before them. However, this time, the classic American images of God, the constitution, and even the olive branch of peace are now absent. Instead, this poster reveals a great deal about what was on the American political agenda at the time: railway expansion, industrialisation, the now prevalent economic divide between the working and middle classes, and also the cultural divide between America’s rural communities in the territories and the industrial heartlands of the east coast. While Debs was very unsuccessful in his campaign (perhaps because Hanford had stolen all his hair), this poster does give us a better glimpse into the cultural upheaval America was experiencing at the time. The age of reconstruction was over, and the age of progress emulated by the gilded age, had begun.

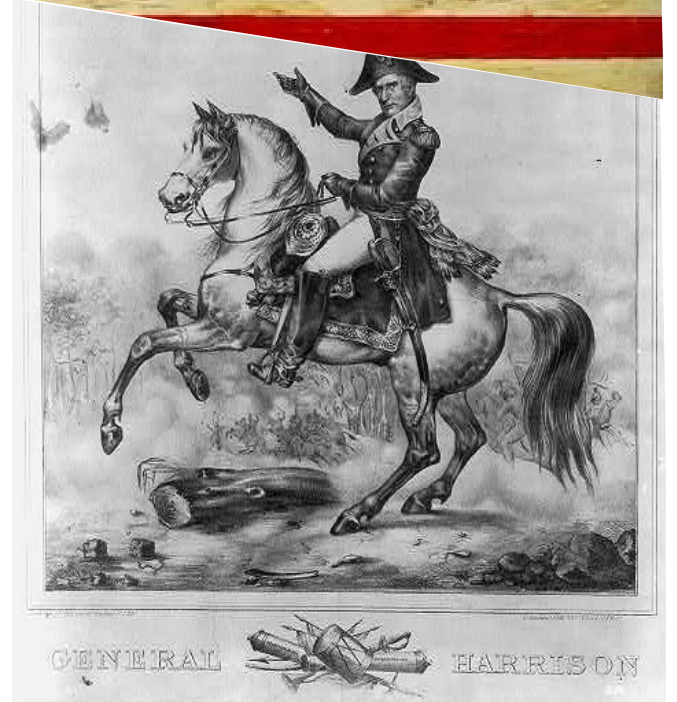

Headline: Flag by Jasper Johns jasperjohns.org  
William Henry Harrison The Library of Congress



Lincoln and Hamlin The Library of Congress

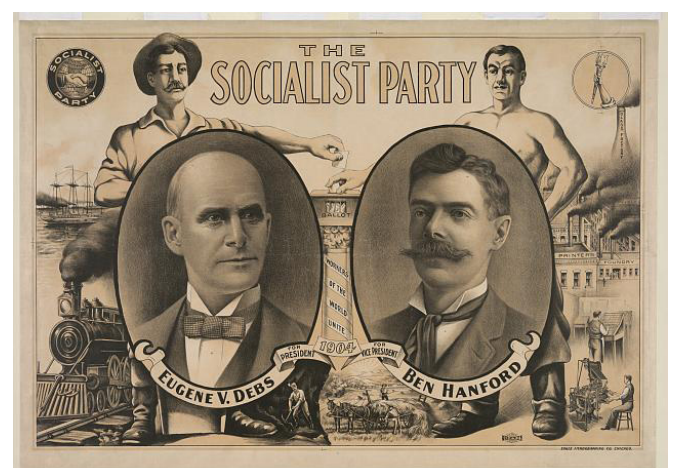

Debs and Hanford The Library of Congress



Washington Crossing the Delaware MMA New York City

### William H. Taft

Here we have heavy-weight US president William Taft portrayed as a man offering “Good Times”. At this point the Republican Party was riding on the wave of popularity set out by T. Roosevelt, and as such you can clearly see that they just could not be bothered to come up with any decent imagery for the man of rather large stature other than the fact he is offering prostitution services, it seems. This is a truly dull poster with none of the theatrics we came to appreciate from the Republican party. Yet, as we shall see, there are worse.

### J. F. Kennedy

The Kennedy campaign pooled all their resources from their mafia connections to present this poster. It noticeably and visually brought a shift in terms of presidential posters’ graphic design. The young, trendy socialite looks like he could even seem happy to run for the job, unlike his predecessors. Not only that, but we start to see the emergence of a new form of power posing – the wistful look. This poster screams optimism, but in subtle tones. It marks the shift of the Democrat party from “gun-toting, freedom-loving, stetson-wearing” policies to the more “East-Coast liberal” approach that we have come to associate with the party today. It is little wonder that his opponent Richard Nixon, famously known for having a face for radio, lost the campaign.

### Ronald Reagan

This is Ronald Reagan. You may remember him for such films as *Bedtime for Bonzo* and *Knute Rockne, All American*. For those who do not, you may remember him as the messiah of American conservative politics, whose book of revelations is still referenced by Republicans to this day. Despite having one of the most successful campaigns of any president, this poster is truly a travesty to man. The flag looks like it was terribly rendered in MS paint and someone turned off the gravity: the stripes crop terribly around his head, and, as a pastiche to his film days, he looks like he is bursting through the poster in a nod to Jack Nicholson in *The Shining*. His looming presence over the White House is undoubtedly what gave Roland Emmerich the idea to make the iconic flying saucer scene in *Independence Day*. The poster itself is one of the worst conjured. However, what captures the average voter is the now familiarly plagiarised slogans, ‘Let’s make America great again.’

### Barack Obama

This poster needs no notes, it is the perfect poster –

it is so perfect it even has its own Wikipedia article.

Designed by artist Shepard Fairey in his classic two-tone style, this poster captures everything that Obama and the Democratic party wanted it to convey: the wistful look, the catchy slogan, and the serious politician. This is the image the Democrat party wanted to conjure in one sublime image. But what don’t you see on this poster? You do not see words like “For President”, “Vote”, and you don’t even see Obama’s own name! But that is part of why this poster is brilliant. It shouts: “This man is bringing hope, change, and progress”, without spelling it out. Not only that, but this is a poster that does not treat the public like idiots. You know you can vote, you know who this man is, and you know for what he stands. What else is there to be said?

### Kamala Harris

Shepard Fairey is back, but this time the impact that Obama had with his poster is now absent. The combination of Harris’ wistful look and odd, arguably uncanny, smile does not convey seriousness in the way that Obama did. It feels more as though she has seen someone that she vaguely recognises at a party and is offering acknowledgement. Not only that, but the slogan this time around, “Forward”, is trivial. With a word like “Forward” you make the viewer ask themselves, “Forward from what?” Biden’s term in office was lack-lustre at best, and this creates the perception that Harris will simply be Biden 2.0, which is really not the case in other areas of her marketing, and it certainly will not be a selling point for the American voter. All this poster does is remind you of the Obama poster and you think to yourself, “Do you remember the Obama years? They were decent”, rather than making the viewer say to themselves, “I bet the Harris years will be good.”



Taft The Library of Congress

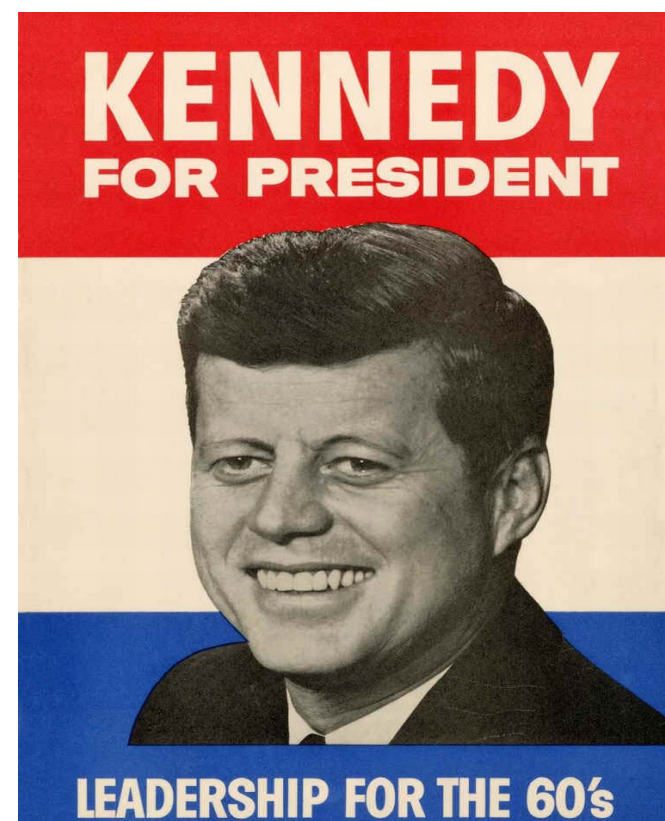

Kennedy JFK Memorial Library



Reagan Ronald Reagan Memorial Library



Obama and Harris Shepard Fairey

**Felix**

# **STEFAN SURVEY**

HOW TIGHT  
WOULD  
YOU GO?





**FELIXONLINE.CO.UK**





## FOOD&TRAVEL

# La Cantina's Oumph!



Felix send their team to review *La Cantina* as one of the newest additions to the JCR.



An order of one chicken, one pork and one vegan protein rice bowl and a vegetarian burrito with free tortilla chips *Charlotte Probstel*

**Food Editor**  
**CHARLOTTE PROBSTEL**

The Junior Common Room's (JCR) newest mexican-themed outlet *La Cantina* is growing traction, selling burritos and rice bowls for £4.50 and loaded Nachos for an even cheaper price of £2.50. Placed adjacent to Starbucks, the outlet does not fail to provide students with a new cuisine and a little more variety, as students choose their ingredients Chipotle-style. *Felix* send its Food & Travel team to try their options and to give their review.

### The Ingredients

You start by choosing a burrito, or the contents of the burrito without the tortilla in a coriander lime rice bowl, and a protein. The current options are



The queue went to the doors of JCR on Monday at 1pm

chicken, pork and an unknown plant-based protein named Spicy Oumph. In the second step, you can choose the following fillings: shredded lettuce,

pickled jalapenos, refried beans, pico de gallo, shredded cheese, shredded vegan cheese, sour cream and guacamole. The final step is choosing one three sauces: mild salsa, the spicier chipotle salsa or lime crema. Free tortilla chips are provided on the bar in front of the outlet.

### Fillings or toppings

The portions were deemed reasonable for the cheap price of four and a half pounds, hence the small portions of each filling was understandable, yet noticeably conserved.

The mild salsa is very sweet; the pico de gallo serves as the better tomato filling. The pickled Jalapenos add an appreciated sourness and spiciness that may not be for everyone, but does elevate the taste of the dish. And the spicy theme does not end there. Surprisingly, the refried bean sauce also provides a little spice. In addition, one member of the team noted that the beans were thick, and stuck to their throat.

The guacamole was unfortunately a disappointment. Unlike at Chipotle or other burrito-outlets, the guacamole is not a premium and is included in the price, hence it would have been difficult for the *La Cantina* to provide a good quality of an usually pricy topping. The guacamole leaves a silky aftertaste that sticks onto the tongue. It works decently when mixed with other ingredients which cover its texture. Otherwise, the

coriander lime rice was well cooked and the tortilla was deemed excellent.

The tortilla chips were the highlight, giving away a beautiful crunch, followed by a subtle corny taste without the typical salty aftertaste. As a snack, the nachos are worth it, since they offer the same fillings and sauces, yet without one of the three provided proteins.

### Protein, protein, protein

The biggest concerns with fast food is protein, as it is costly to provide, often skimmed upon, and varies highly on the source. The amount of pork and chicken was lower than expected, while the amount of Spicy Oumph was enough for those who chose it.

The team guessed the vegan alternative to be seitan, as some pieces were chewy, and the others melted apart easily, however they are soya based kebab strips from the company *Oumph!*.

### More veggies, fewer sauces

*La Cantina* provides ample sauces and all the fundamental ingredients of a burrito, yet a larger selection of vegetables and beans could be an improvement. The sauces overpowered the taste of other ingredients and the orange sauce was not a favourite for its ranch-like cheesy taste. Our suggestion is to choose on sauce per bowl or burrito, even the staff asks if you want multiple sauces, but not for the loaded Nachos.

## Food for Health

# Squash & Pumpkins

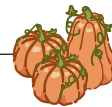

**Food Editor**  
**CHARLOTTE PROBSTEL**

Halloween ended last night, and yet there is few reason to ignore pumpkins and squashes during the late cooling Autumn season.

### Nutrients & Benefits

The orange flesh is rich with beta-carotene, a form of vitamin A found in plants. Vitamin A is a fat-soluble vitamin usefu to maintain vision, a good immune system and reproductive health. A lack of Vitamin A may increase the risks of age-related macular degeneration, a loss of central vision, or Xerophthlamia, the inability to see in low light.

### Butternut Squash Soup

A delicious vegan (if you ignore the butter to taste) butternut squash soup by *Cookie & Kate*, is an excellent way to consume Butternut Squash.

You will need an oven to roast the butternut, a large soup pot to mix everything, and a blender/blending stick to break down the soup. The ingredients are a small list of butternut squash, vegetables, spices and vegetable broth.

### Steps:

1. Cut the butternut squash into pieces, drizzle with oil and spices, and roast in the oven for about 45 minutes.
2. In a pot, cook vegetables.
3. Add roasted butternut flesh, cooked vegetables, spices and broth to a blender or blend in the pot.
4. Serve

Scan the QR code for the full recipe.



## COMMENTS



# 2024 US ELECTION SPECIAL

## Editor's note

What screams Halloween more than the spooky, scary power transition across from the Atlantic? The now ritual “blue or red”

dichotomy has come to be dreaded more than the old “trick or treat”, although both traditions are in a tie when it comes to their ability to turn grown adults into children.

With Donald Trump and Kamala Harris

in a polling deadlock, the Comments team has put together a selection of pieces weighing the changes, probing the implications and investigating the actors of the world's most dangerous game of heads-or-tails.

All eyes are on the US, as the repercussions of this election will affect all spheres. Some estimate the sum of bets at an eye-watering \$2 billion. Sadly, the editor reckons the only foolproof bet is the one against a peaceful transition.

## With great momentum, come even greater expectations

Kamala Harris's celebrated nomination as the Democratic candidate in the 2024 US presidential elections in August gave her popularity a boost big enough for it to hover marginally above Donald Trump's in the national polls. In the last two months, her ratings decreased slightly, while prospective votes for Trump were slowly gaining in numbers. The numbers do not explain why Harris is losing support, despite her well-received welcome to the presidential stage – yet it may be time to consider the position Harris was placed in and the expectations she was supposed to meet.

The catastrophic presidential debate on June 27 highlighted Joe Biden's old age and lack of fitness, both mentally and physically. At the age of 82, this is no surprise. At the time of his election, Biden was the oldest President to ever enter office; Trump was in second place at age 70. Three weeks later on July 21<sup>st</sup>, after weeks of public scrutiny and a large online movement pushing him to resign from the elections, Biden announced his withdrawal, opening the space for his Vice President.

Harris entered the scene with “momentum”, as the

headlines read. In a time of chaos within the Democratic party, she quickly began her presidential campaign, touring states and raising significant funds and online support. As the new face of the Democratic party, the policies of which align with those of the Biden administration, Harris was placed on a liberal media-supported virtual pedestal as a blue saviour rivalling a red egoist.

In all agreement, Harris is an impressive woman – a well-educated lawyer who went from prosecutor to district attorney, attorney general, and finally US Senator within 13 years, often as the first female or person of colour – and it is because she is a woman that her background, current efforts, attitude and policies are under heavier scrutiny. It is because she is not a white male that there is an air of uncertainty to her capabilities.

Yet, within a few months, she raised over one billion USD, debated

elegantly against a bigoted man who focused more on debilitating her image than on the wellbeing of his supporters, and spent the few opportunities to present herself in the spotlight giving inspiring speeches and interviews. The expectations imposed on her, despite her intelligent nature and positive stance on human rights such as healthcare and reproductive rights, were not met in the minds of the people. What happens when your expectations are high, and you meet a human? You get disappointed. It's like every Bumble date you will ever go on.

Clearly, this is not Harris's first time in the spotlight. She has had her opportunities the last four years to present herself, where she was given a rather

unfavourable rating as Vice President. However, once a candidate, her favourability ratings improved, contrastingly to the steady unfavourable rating of her red opponent. Studying Harris, and not her administration nor the claims made by others, as well as the high-pressure environment she was placed in the last four months, was the test that proved she can present a strong front when challenged by obstacles coming from every corner.

## Brought to you by

Editor **GUILLAUME FELIX**  
Designer **JULIETTE FLATAU**

“With great momentum, come even greater expectations”

“Celebrity endorsement trends”

“A masterclass in marketing”

“The second messiah, or how Trumpism weaponised religion”

“Harris and the leftist vote”

“Hedging elections outcomes: market implications and historical trends”

**EMILY JACOBI**

**HIMA FAZEEL**

**RUBY LYDFORD**

**TARUN NAIR**

**ANUBHA SUKHADA BAL**

**MITCHELL ERDLE**

## Celebrity endorsement impacts

Celebrity endorsements have long played an influential role in the US elections, and this year's iteration is no exception. This year, many celebrities have taken to social media to proudly share their vote and encourage their followers to participate.

A notable endorsement came from singer Taylor Swift on Instagram, who expressed her support for Vice President Kamala Harris after the second presidential debate. Swift made a post encouraging her 283 million followers to register to vote, which led to 340,000 visits to Vote.gov (the Federal voting registration website) within 24 hours. Her endorsement disproportionately increased electoral engagement among young voters – an underrepresented group. By bringing pop culture into this election, Swift helped the Democratic Party reach a younger audience, amplifying its message to the masses. Her support also encouraged other celebrities to voice their political views.

The Democrats are not alone in leveraging these endorsements. Former Republican president Donald Trump has garnered support from high-profile figures like that of

billionaire entrepreneur Elon Musk, who has voiced his agenda through social media and attendance at Trump's rallies. His \$75 billion donation to American PAC (the Trump-supporting political action campaign he started) highlights how celebrities are not just expressing voter support but are also directly involved in campaigns. This financial backing blurs the lines regarding the extent of celebrity involvement in modern elections, potentially skewing the democratic process. Moreover, this reliance prompts questions about the authenticity of political messages and the celebrities' true motivations.

The impact of celebrity endorsements on this election is undeniable. Both Trump and Harris know that there are one of the best ways to garner support for their party in a country as diverse as the US. The vocal and financial backing not only amplify campaign messages but also mobilise voter turnout, disproportionately among certain demographics. The intersection of celebrity culture and politics highlights the evolving nature of modern elections, where the influence of celebrity figures can undermine the democratic process.

## A Masterclass in marketing

I am a great fan of the Oscars and the Grammys. I love to predict the winners, critique the campaigns, analyse the odds, and then watch the long-awaited ceremony and exclaim an ill-mannered sentiment at the television proclaiming the Academy is rigged. If Kamala Harris were campaigning for Best Picture, or Album of the Year right now, I would certainly say that she has this secured, and that the Academy is greatly in her favour. This is not the case: she is in the running for the next president of the United States. This is not voted on by the Academy, or any academy, but by the American citizens who are registered to vote.

Harris' and Trump's marketing feel representative of what liberalism and conservatism are at their definitions: she is focusing on the shiny new (online) world of the pop culture stratosphere; he is living in the history of traditional presidential campaigns.

Harris's campaign includes the tropes of modern marketing, starting with endorsements from a wide array of public figures (Billie Eilish, Lizzo, Taylor Swift). This is an ideal publicity tactic. It reaches out to fanbases; Harris's image aligning with these singers and actors that we see every day. However, it could be argued it creates this narrative according to which Harris' campaign is for these public figures. It feels as though one is in school, and the popular classmate has got all their popular friends to endorse them. Although I might like them, are they appealing to me? Is Billie Eilish's situation aligned with my own?

While Trump compromises on many of my own values, he is attempting to speak to the everyman, the all-American. There is, however, the notable use of Elon Musk. Yet even he is acting as a great logic-based philanthropic billionaire, donating \$1 million a day to a registered voter in key swing states until the presidential election. He speaks to the average man.

Trump's campaign lives in the classic Republican ideology of the American dream, appealing to every class and every man, while actually supporting and benefiting bureaucrats, as well as those already in power. And I don't think Harris is doing this. Harris is focused on songs, and music, and Beyonce, and Meryl Streep on a zoom call. Donald Trump got shot for - in his mind and the future voters of the Republican party's minds - America. Donald Trump was photographed, fist in air, getting shot for the people of America – and it looks good on paper.

Trump's marketing is conversative – yes. It calls back to classic photography, to Ronald Reagan's readapted iconic “Make America Great Again”, even to the countless assassination attempts of the time. It is rooted in the way things are and have been. It is not modern, it is not appealing to the pop-culture side of young people, but it works.

Harris seizes modern marketing by the throat: using TikTok, memes (namely the “coconut tree” and “brat summer”). She engages a young audience. CIRCLE estimates that only half of the youth (18-29) voted in 2020, an 11-point increase from 2016, yet still opportunistically low. She is intelligent to focus here. But is the marketing really targeting this? I would vote for Kamala Harris, as I believe most young people would, but *will* young people vote for Kamala Harris? If it were a pop-up on their screen on TikTok on November 5th, sure. But registering and going down to the voting booth is a different thing.

Trump's marketing is pressing. He gets people riled up so that he knows that they're going down to the voting booth, because they truly believe that that Donald Trump will make America great. Harris is making Reels and tweeting “Kamala = brat”. Is that going to make someone go down to the voting booth? No, it's going to achieve publicity – to commendable heights previously unseen – and a repost of a six-second clip.





## The second messiah, or how Trumpism weaponised religion

The party of choice for the white practising Christian, Republicans have had especially strong support from white Evangelical Christians – in every election since 2000, a greater proportion of them have voted for the GOP ticket than any other religious demographic. This has only grown since 2016, with as much as 85% of white Evangelical Protestants registered as Republican voters in 2023, according to a Pew Research poll.

Donald Trump's Republicans, unlike the old guard, have succeeded in courting the pious vote by using religion as a bugle call to galvanise their supporters. This fusion of far-right politics with fundamentalist Christianity has given rise to Christian

nationalists like House Rep Marjorie Taylor Greene, who vehemently believe Christian traditions are under attack by external antireligious forces, and religion and politics are one and the same. For them, Trump is a messianic leader, and keeping the Democrats out of Congress and the White House is doing battle with evil. The January 6 coup d'état, where the former president incited supporters to charge the Capitol and prevent the certification of the 2020 electoral votes, demonstrated the lengths they are willing to go to for this end: many rioters held posters declaring that Trump was divinely anointed to be president, even likening him to Jesus.

There are economic factors at play

as well: US counties in the lowest quartile for median household income are overwhelming concentrated in the Bible and the Rust Belts, regions with a high prevalence of Evangelist Protestants. This gives an insight – one championed by JD Vance in his controversial autobiography *Hillbilly Elegy* – into the working-class white voter, who feels politically neglected and left in the dust of a reportedly strong economy under the Biden administration. It also explains why religious voters are willing to look the other way for a candidate who, at least ostensibly, cares about their plight.

The ramifications of a second Trump term on key religion-adjacent issues are

apparent just from what the party has managed to do so far. Their biggest achievement so far has naturally been the overturning of *Roe v. Wade* in 2022 by the conservative majority of the Supreme Court, allowing states to legislate on abortion as they see fit. As a result, abortion is currently banned in 14 states, and despite a nation-wide pro-choice campaign, South Dakota is the only one of these which will have the issue on the ballot next month. With a Senate majority looking likely and close races for the presidency and the House, Republicans have the chance to seize control of the executive and legislative branches. If they do, all eyes will be on them to see what kind of direction they will take the country in.

## Harris and the leftist vote

As a leftist, there have always been ample reasons not to support the Democrats, but I understand that for many left-wing and liberal Americans, the need to begrudgingly mark that blue box has gotten more urgent – perhaps than ever before – this time round, at least in swing states. However, in this election, the problems in the Democratic party are much more apparent, with their stance on Palestine in particular pushing away the leftist and non-white electorates.

There is, obviously, a more qualified candidate between Trump and Harris, however she seems to be ignoring the leftist voter bloc almost entirely, in an attempt to pinch some swing voters. This is evidenced by her convoluted stance on gun control (declaring that she is a gun owner and will not relinquish rights to ownership), and her insistence on maintaining financial support for Israel while again confusingly

declaring that Palestinians are in need of humanitarian aid. Additionally, Harris has accepted endorsements from prominent neoconservatives like Liz Cheney. The question for Harris now is whether she has correctly gauged which group is more important for her success, or if this choice will cost her the election.

In the past, the leftist voters do not appear to have been a group influential enough to cost the Democrats an election – in 2016, the issue was Trump's populist mandate, as well as poor turnout combined with the failures of the electoral college system. This time, however, it is not so concrete. With news of Palestine protests in American universities making headlines, alongside third-party candidates gaining support, it is not clear whether ignoring one edge of the Democratic spectrum is viable for Harris. Leftist voters, alongside

Arab American voters are, justifiably, becoming increasingly more unwilling to *Vote Blue No Matter Who*, and it remains to be seen if enough will still vote tactically

to assure a Harris victory.



# Hedging elections outcomes: market implications and historical trends

In just over a week, Americans will head to polls to elect their next president and Congress. Currently, polls show former President Trump and Vice President Harris in key swing states deadlocked with no more than a percentage point separating the candidates.

The world will certainly be watching, which in turn means the markets will be watching. Much of the economic discourse in America revolves around who would be better for the market. In the UK, our own economic interests may also be shaped by the outcome. How might this election influence the US markets, and what ripple effects could we expect here in the UK?

## S&P 500 Historical Performance

Typically, speculation around US stock market volatility leading up to the election is overblown, apart from market crashes in 2000 and 2008. When considering the 100 days before and after an election, the US markets are calmer than non-election years. Despite this relative stability, questions remain about whether the party in power has a short-term impact on market performance. Recent analysis by U.S. Bank investment strategists examined 75 years of market data for the three months following past elections. Their findings reveal certain scenarios where the market impact has been statistically significant, depending on which party takes office.

## Positive Market Outcomes

Within the positive market outcomes – two situations were observed. Either Democrats control the Presidency, with full Republican control of Congress, or Democrats control the Presidency and there is split control of Congress. When comparing the 3-month returns of the

results above to non-election years, the S&P 500 (a market index tracking the performance of the largest American companies) outperformed by about 1.7%.

## Negative Market Outcome

The underperformance scenario was found to be correlated with Republican control of Presidency with full Democratic control of Congress. These results may complicate any bloviating by either party that the market views their policies better than their opponent's, but one thing is clear, split control is something at least the S&P 500 values.

## UK Implications

Similar to the US, you can expect UK markets to be rather muted in the short-term following the election next week. Despite this, each candidate's platform may have tangible long-term effects on British market conditions.

## Trump Policy Proposals

Economically, there are a few of Donald Trump's policies that could have implications here too. Tariffs are a large part of Trump's economic platform, with a proposed increase from 5% to 10% for the UK and the rest of Europe. This may cause some trade relation issues between the two countries and could have tangible effect on UK access to

US markets.

Outside of tariffs, Trump has also stated he plans to deregulate the oil and gas industry. Deregulation in the oil and gas industry may be attractive to UK investors within the energy sector and UK companies with offices in the US concerned about energy prices. Lastly, he plans to reduce trade barriers for US agriculture. This could cause the UK to alter its food and agricultural standards, and those farmers that still operate under strict EU rules might have to change their practices.

## Harris Policy Proposals

When considering Kamala Harris's effect on the UK economically, the Harris administration would likely continue

the policies set forth by the Biden administration. No meaningful alterations to trade policy are a part of her platform and she has no intention of deregulation in significant sectors like oil and gas or agriculture. This may be preferable to some in the UK as exporters can expect business as usual and those within the clean energy and sustainability sector can expect added investment interest and US government subsidies in the space.

Ultimately, speculation is just that – speculation. Without a party gaining full control of Congress and the Presidency, you can expect changes to come slowly outside of the few levers a president can pull to change the executive branch's posturing on key issues. November 5<sup>th</sup> is quickly approaching and in just over a week, we will have the 47<sup>th</sup> president and the 119<sup>th</sup> US Congress.



## FILM&amp;TV

# LEAFF opens with Escape

The opening gala of the London East Asia Film Festival invited icons, celebrated directors, and curious students to view the Korean action-thriller.

## Film Writer

CHARLOTTE PROBSTEL

Warning: spoilers.

The London East Asia Film Festival (LEAFF) opened its two-week long event last Wednesday, at the Odeon Luxe Cinema in Leicester Square, with the Korean action-thriller *Escape*, a heart wrenching story of a North Korean soldier stationed close to the Korean Demilitarized Zone (DMZ) and his attempted escape into South Korea. The King's College London Singaporean Society was gifted 15 free tickets by LEAFF for them and their friends, hence my friend extended the invitation to me.

At 6:30pm, we were granted access into the venue; a rather spacious red carpeted corner, with a wall tiled with sponsor's names, gradually filled with celebrities. Hong Kong actress and film director Sandra Ng was one of those celebrities who caught my eye, with her welcoming smile and open body language. Eventually, we

were asked to move to the circle floor as more celebrities entered the venue.

On the first floor, we caught a glimpse of special guest and actress Lim Ji-yeon (second female lead in the Korean thriller series *The Glory*) before we were asked to head to our seats. At seven o'clock, the show began with some music playing on the pipe organ, followed by speeches and awards. After an hour, the film eventually began.



*Escape's* opening scene was thrilling, with my friends commenting that “this is where the entire budget went to.” It introduces our protagonist Im Kyu-nam, played by Lee Je-hoon, a North Korean soldier stationed at the DMZ. Every night, he works on his plan to escape, drawing a map and hiding his tools in different places along his route. Close to the date he has chosen, he is forced to leave early due to the oncoming rainy weather, which would wash away the locations of landmines. Had he found success, the movie would have ended after ten minutes: instead, the audience follows Kyu-nam through a series of roadblocks, narrow escapes, and tear-jerking scenes of characters we come to love, before the movie ends with Kyu-nam shot in the back, inches away from freedom. How he got there is up to you to find out.

The director of the film, Lee Jong-pil, gave a short speech before the movie. He mentioned that “every film has a deeper meaning” and while this does apply to *Es-*

*cape*, he was keen to point out that he wanted to make the film fun and entertaining. As such, he dusted the film with irony, slipped in modern-day references, humiliated totalitarian dictatorships, and even added a romantic Russian queer love story for our antagonist Major Lee Hyun-sang, played by Koo Kyo-hwan (*Peninsula*, *D.P.*) a character more loved than despised by the audience.

Overall, the film is a must-watch thanks to its cinematography, its score celebrating classical composers such as Strauss and Chopin, the film editing, and the costumes for the upper-class of the North Korean regime.



Sandra Ng on the red carpet Charlotte Probstel

Lim Ji-yeon winning Best Actor at LEAFF (top), photographed on the red carpet (bottom) Charlotte Probstel

## BOOKS

# Books' Guide to Reading More

Life is about to get busy. Don't forget to read!

**Books Editor**  
**ADITI MEHTA**



### 1. Make reading part of your routine

Just like brushing your teeth or scrolling through Instagram, make reading a non-negotiable part of your daily routine. Pick a time: a chapter before bed, a few pages over breakfast, or a deep dive on the tube home. Integrating reading into an existing daily habit makes it feel less like a chore and more like a natural phenomenon. Stop making excuses.

### 2. Carry a book everywhere

Yes, take this opportunity to look mysterious whilst on the tube or sipping on an overpriced coffee (or Blueberry Matcha Latte at Blank Street, I know the crowd) at your local cafe. If you take your book wherever you go, you're more likely to reach for it than indulge yourself in a mini doom-scroll. That's the theory, anyways.

### 3. Or at least, make a reading accessible for yourself

If you don't want to "lug a heavy book around", download an e-book on your

phone or tablet. It may not be as cool, but it is certainly more convenient. Via the College's subscription to the Libby app, you can download a practically unlimited pool of books for free. If you would rather reduce other digital distractions, you could even consider investing in the likes of a Kindle.

### 4. Pick something you enjoy!

Who cares if you are fiend for BookTok! (I care, but that is currently irrelevant). The key to making reading a sustainable habit is by wanting to read, and the most effective way to do that is to choose a book that interests you – not one that makes you want to claw your eyes out. You'll find it's actually great way to unwind.

Personally, returning to my favourite books reverses reading fatigue. In fact, I just reached for mine last week...

### 5. Set simple goals

Aim for 10-20 pages whenever you find a spare moment. Reading in bite-sized chunks makes it less overwhelming and helps you gradually build a habit. You generally have more free time than you lead yourself to believe.

Along with this, set achievable goals,

like reading for at least 60 minutes per week or finishing one book a month.

By setting realistic goals, you're more likely to stick with reading. Don't get hung up on numbers, though. Ultimately, it is not about quantity but the joy of finally reading.

### In summary

It can be hard to follow through with a

commitment to reading, but by reducing self-prescribed barriers and increasing personal motivation, you can make your reading goals a reality.

A few months down the line, you may just find a correlation between reading, feeling enriched, enjoyment, and a real sense of accomplishment. At least I know I do.

Happy reading!



## LIBBY

Libby is a free app where you can enjoy e-books, digital audiobooks, and magazines from your public library.

The Imperial College Libby collection has over 2,000 items including best-sellers, prize-winning fiction, history, health and wellbeing, and titles in Spanish, French, German and Italian.

## HOW TO JOIN LIBBY

1. Download the Libby app from your app store
2. Log in with your Imperial username and password
3. Borrow recreational audiobooks and e-books on your phone or tablet.

It's as easy as that!

# Feb Senton runs for President

## Catnip Writers NEGAFELIX

**D**ark horse Feb Senton has pledged to take over the role of Imperial President from Bugh Hradý. Senton was previously the president of UWE Bristol and plans to align Imperial College with his new “regressive thinking” approach. NegaFelix had the opportunity of meeting with Senton in the *Felix* office to discuss his policies, accompanied by his campaign manager Jimmy “The Vice” Valentino, known painter and decorator, who previously worked with Senton’s seconder, Emmanuel Frederick.

NegaFelix first questioned Senton on his proposition that “fish and eggs be considered part of the vegan diet”. He told us that this radical idea came from having his first lunch at Plantworks. “The lack of options was shocking, really,” he said. “I propose we give them something that tastes good. Avocado maki is shit.” Our Vegan Affairs Correspondent, Blex Aull, asked for clarification on how this policy would be tackling the animal rights issues at the core of veganism. Senton assured us all his policymaking follows an organic approach, and he and his team took time to interview multiple fish. A newlywed yellowfin couple from Ocean Catch declared, “We don’t mind if we’re sashimi grade tuna, it’s classy and expensive.” Some young, male salmon even extended this sentiment to smoked salmon, as they too were partial to a cigarette. One particular Pollock told us that “sushi is fine, but crabsticks are offensive, discriminatory, and group together certain fish cultures just with segregation in mind. I’m not an imitation crab, I’m a proud pollock.” Senton assured us that all fake crab sticks would be banned from the campus to respect this wish. NegaFelix is still waiting for Plantworks and VeganSoc to give a statement on how they will deal with this sudden increase in omega-3 fatty acids.

Despite backlash, Senton remains steadfast on his decision to introduce VAR into College examinations. The VAR rooms for the examinations taking place in The Great Hall would operate from the Silwood Park campus in Berkshire. Previously with VAR test-runs there has been a commotion that the exam invigilators may have had connections to UAE officials, but Valentino told NegaFelix “You didn’t hear nothin’ about no UAE officials, capisce?” One student argued that their answers did not have any “clear and obvious errors”, so it should

not have gone to VAR at all, as it “interfered with the natural flow of the course”. IC Union Deputy President (Education), Paylor Tomfret, put out a statement to Senton this week: “Why are they still drawing the lines in Silwood? It should be semi-automated like at LSE.”

Mr Senton then drew fire at Imperial’s smoke-free policy. “I think it’s cultural discrimination that we are attacking smokers’ rights. I would not only bring back casual smoking on campus but triple it by building a coal power station in the Beit Quad to choke the local atmosphere. Subsequently, I would turn the Union Bar into an executive smoking lounge. Non-smokers can stay in FiveSixEight with all the other virgins.” Outside of this, Senton has numerous policies involving equality, even touching on the hotly debated case of public bathrooms. These policies involve banning all single-sex toilets, in favour of public defecation on the Beit Quad lawn, re-immersing in the College culture that “died with COVID.” Mr Senton also wishes to abolish all unisex toilets in favour of “Sex Toilets”, as an act of appreciation for the Imperial dogging empire.

Next up on Mr Senton’s hit list was White City Campus. “Nationalising the White City Shuttle bus is near the top of my priority list – I feel as though it is integral to worsen travel times and to create irregularities in the timetable.” With the growth in students emigrating to White City becoming an

issue, including as the Maths and Com-

puting departments, Senton proposes a scheme to send these students to Rwanda to “begin more productive research careers.”

Finally, Mr Senton has promised to establish the charitable organisation UNIFEB to assist the impoverished at Imperial. “I often see residents of North End Road and Shepherds Bush walking around campus with no shoes, no clean water, or even a balanced diet. It is paramount we address these growing concerns of the “Shit-home crisis”.”

NegaFelix approached Mr Jimmy “The Vice” Valentino for a comment on Senton’s policies but he declined, only saying, “Eh! Oh! Who says I know about these policies? Forget about it.”



# Horror-scopes: your Halloween costume



## ARIES

Pregnancy Test Scare: if the costume comes together you won't need plan B.



## TAURUS

Whiteface: also known as clown makeup.



## GEMINI

Closeted Rugby Bros: a duo costume for the twin sign. A penis in the mouth for accuracy.



## CANCER

Working Class: make sure to shift your accent in front of certain crowds.



## LEO

Prostate Exam Patient: make sure you enter the party through the back door.



## VIRGO

Polycule: group costumes are always fun with your friends.



## LIBRA

Third Wheel: there's no space for you on the sidewalk, but you live life on the curb!



## SCORPIO

Celebratory Wank: let your friends know you've got everything in hand.



## SAGITTARIUS

Cancelled Felix Editor: not allowed in strip parties.



## CAPRICORN

A Loving Father: we can't give any details on this costume.



## AQUARIUS

Not Drinking Tonight: constantly remind people, and then get shitfaced.



## PISCES

Peanut Butter: you recently went through a break up.

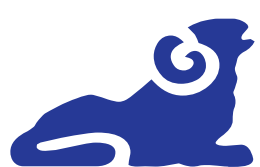

## ARIES

This week conjunctivitis makes your eyes terrifyingly red just in time for Halloween



## TAURUS

This week you attend Actors on Actors with Paul Mescal and use your phone Naomi Campbell-style



## GEMINI

This week you start charging your partner for access to your tits on the Government's advice to tax milk based beverages.



## CANCER

This week you celebrate your local pint costing £5.58 instead of £5.59 by buying ten pints, spending £55.80.



## LEO

This week your Tinder date suggests a threesome when you ask for Angela at the bar.



## VIRGO

This week you rightfully put Liam Payne on your Dia de los Muertos altar.



## LIBRA

This week your friends convince you to go to the party as Greek legend Cassandra - you see it going badly, they don't believe you.



## SCORPIO

This week your entire flat boycott the party after being informed best costume is "Olivia Rodrigo" rather than your golden boy "Vini VG".

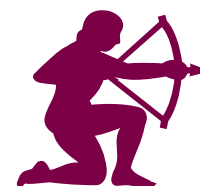

## SAGITTARIUS

This week you STOP and THINK before you TOP a TWINK.



## CAPRICORN

This week the £5 rail card increase is the nail in the coffin for your long distance relationship.



## AQUARIUS

This week you enter the Feb Senton look-a-like convention for a quick 50 quid but lose when Feb Senton actually shows up.

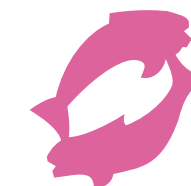

## PISCES

This week you stop your friend from making a cultural faux-pas after he takes your brown boot polish.

UNION & SOCIETIES



# Societies Announcements

Societies Editor

CHARLOTTE PROBSTEL

## International Foodies Society



**Event:** Left Bank Bordeaux Cup  
**Location:** Online  
**Date:** TBD  
**Stand & End Time:** TBD  
**More Information:** If you are interested in taking part of the LBBC cup to represent Imperial, please email [IntFoodSoc@ic.ac.uk](mailto:IntFoodSoc@ic.ac.uk). We will send you more information and ask you some questions about wine!

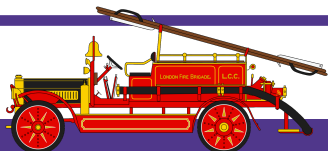

## Imperial College Vintage Motor Clubs

**Event:** VCC Brighton Run  
**Meeting Point:** ACEX 108  
**Date:** 3<sup>rd</sup> November 2024  
**Start & End time:** 7am – midnight  
**Who:** Members only  
**Price:** FREE  
**More Information:** Boanerges, the 1902 mascot of the C&G college will be attempting to drive to Brighton while Jezebel and Clementine, the RCSU and RSMU mascots follow along to support. It's a fun day of driving alongside hundreds of pre-1905 Vehicles and a great chance to see some of the earliest examples of the motor car!  
**If interested:** Email [rccsmc@ic.ac.uk](mailto:rccsmc@ic.ac.uk)

## ICSM Radiology

**Event:** Annual Conference  
**Location:** King's College London (Guy's Campus)  
**Date:** 24<sup>th</sup> November 2024  
**Stand & End Time:** 9am – 5pm  
**More Information:** "Programme of the day includes: Fascinating talks from pioneering researchers and enterprise leaders, AI in Radiology panel discussion, Afternoon activities including Ultrasound Project workshop and Virtual Reality in Medicine and Surgery hands-on VR workshop, Anatomy Cup Quiz, Essay competition. Lunch included in ticket price!



**Tickets:**  
**In collaboration with:** UCL, Kings, SGUL and Barts

## Imperial Entrepreneurs



**Event:** Imperial IdeaForge  
**Location:** CAGB 200  
**Date:** 2<sup>nd</sup> November 2024  
**Start & End time:** 2pm – 4pm  
**More Information:** Want to be a tech founder but don't know where to start? Join our 5 month incubator and build a startup from the ground up, no experience required.

RAG



**Event:** Bungee Jump on Queen's Lawn  
**Location:** Queen's Lawn  
**Date:** 13<sup>th</sup> November 2024  
**Start & End time:** 11am – 4pm  
**Play ends:** 10pm  
**More Information:** The Raising and Giving Bungee Jump will be the opportunity for some brave students to take a dive right next to Queen's Tower. All profits go to our three charities: Saint John Ambulance, Alsama, Refugee Action.



**Tickets** are now live on instagram

@imperialcollegerag

## IC KPOP

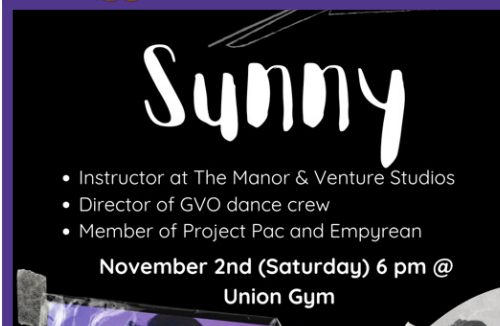

**Event:** Sunny's Dance Class  
**Location:** Union Gym, Beit Quad SW7 2BB  
**Date:** 2<sup>nd</sup> November 2024  
**Stand & End Time:** 6pm – 7.30pm  
**Who:** Members & non-members  
**Price:** £8/members, £12/non-members  
**More Information:** We're kicking off the November Workshop Series with Sunny, an experienced instructor at The Manor & Venture Studio! Sunny will be teaching his own choreography to a popular K-pop track, don't miss out on the chance to learn, groove, and level up your moves!

## Climate Entrepreneurs Club



### ImpactTech Kickoff

#### EVENT DETAILS

**DATE**  
15th November 2024

**TIME**  
18:00 - 21:00

**LOCATION**  
The Royal Institution  
(21 Albemarle St, London W1S 4BS)

**WHAT WE'RE ABOUT**  
The ImpactTech Kickoff is an event aimed at connecting climate-conscious students across the UK with startup founders who launched ClimateTech companies during their university years.

Our goal is to inspire action and demonstrate that everyone can make a difference - now is

#### PAN

**SERGEI M**  
• Founder of  
• Ex-softwa  
and X, the

**MAURICE**  
• Co-found  
Planet Sm

**SHILADI**  
• Co-found  
Technolo  
• Forbes Eu

**Event:** ImpactTech Kickoff

**Location:** Royal Institution, 21 Albemarle Street, London W1S 4BS

**Date:** 15<sup>th</sup> November 2024

**Stand & End Time:** 6pm - 9pm

**Who:** Members & non-members

**Price:** FREE

**More Information:** Join us for the London ImpactTech Kickoff on November 15th at the Royal Institution, Mayfair, where you'll hear from successful climate-tech founders and network with like-minded students and entrepreneurs. Don't miss this opportunity to participate in panels and networking sessions, and gain insights from industry leaders!

## ICSM Drama



**Event:** Autumn Play: Peter and Wendy

**Location:** University Concert Hall (UCH), Beit Quad, SW7 2BB

**Date:** 27 - 30<sup>th</sup> November 2024

**Doors open:** 7pm

**Play starts:** 7.30pm

**Play ends:** 10pm

**More Information:**

Join ICSM Drama for our autumn play, a decolonial and feminist interpretation of Peter Pan and Wendy!

# Imperial quiz novices battle it out in Southampton

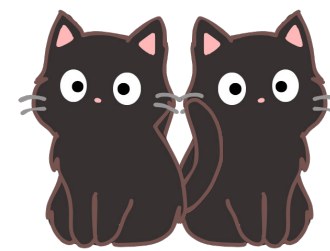

Imperial B team and Southampton A team during one of the morning matches Jamie Burchett

## Societies Writer DAVID LATIMER



Perhaps inspired by Imperial's run-away performance on University Challenge this year, Imperial sent three teams, two of which composed entirely of freshers, to Southampton for the annual ACF Fall Quiz Bowl on the 19<sup>th</sup>. The competition was open to many universities from the south of England including Oxford and Cambridge. Typically, each team contains four players to give the teams a wide berth of subject knowledge, however many teams were a few players short; Bristol team B for example only had two players. Despite this, they still gave a stellar performance.

For fans of University Challenge, ACF Fall had an identical game structure. Teams fought to buzz in quickly in many initial "toss-up" questions in order to earn points - and three bonus questions - for their team. Each game lasted around 40 minutes and featured

20 toss-ups. The tournament was also held in many other places on the same day, such as Durham (for all of the northern universities) and even many places in the US, for example MIT.

After a long, full day of quizzing, Imperial came out the other end with an alright presentation with Oxford's first team securing the victory. "Everyone had great performances," Bethany, the Chair of Imperial's Quiz Society, commented. "There were certainly some stand-out buzzers had by all. I think the key thing is that everyone enjoyed it."

Bethany is a third-year student at Imperial and has been a member of Quiz Society since her first year after she attended their stall at the Freshers' Fair. In the years following, she has attended several tournaments as a contestant and been a moderator for many more. An advocate for new recruits, Bethany was one of the people managing this year's Freshers' Fair hoping to attract more people in the same way she joined.

Competitions like ACF Fall feature a wide range of subjects that can

be asked ranging from STEM topics to European history and literature, "there's something for everyone." Some questions that always stump contestants are the ones about classical music; if that's something you have a penchant for, then consider joining the society. The tournament took up the whole day with a lot of that time dedicated to travelling.

The next novice tournament, however, is being held at Imperial College London's campus itself at the end of November with applications open until the week before. Quiz Society hold weekly buzzer practice sessions every Monday at 6pm in the City & Guilds Building and they're always looking for fresh faces who are interested.

Imperial's winning University Challenge teams all had their start in the quiz society and some still manage parts of it like Justin Lee, a de facto campus celebrity following his many appearances on the programme. For updates and information, make sure to follow @imperialquizzesoc on Instagram.



# PUZZLES

**Puzzles Editor**  
**IVIN JOSE**



## CROSSWORD



"Orange you excited for halloween?" (3 pts.)

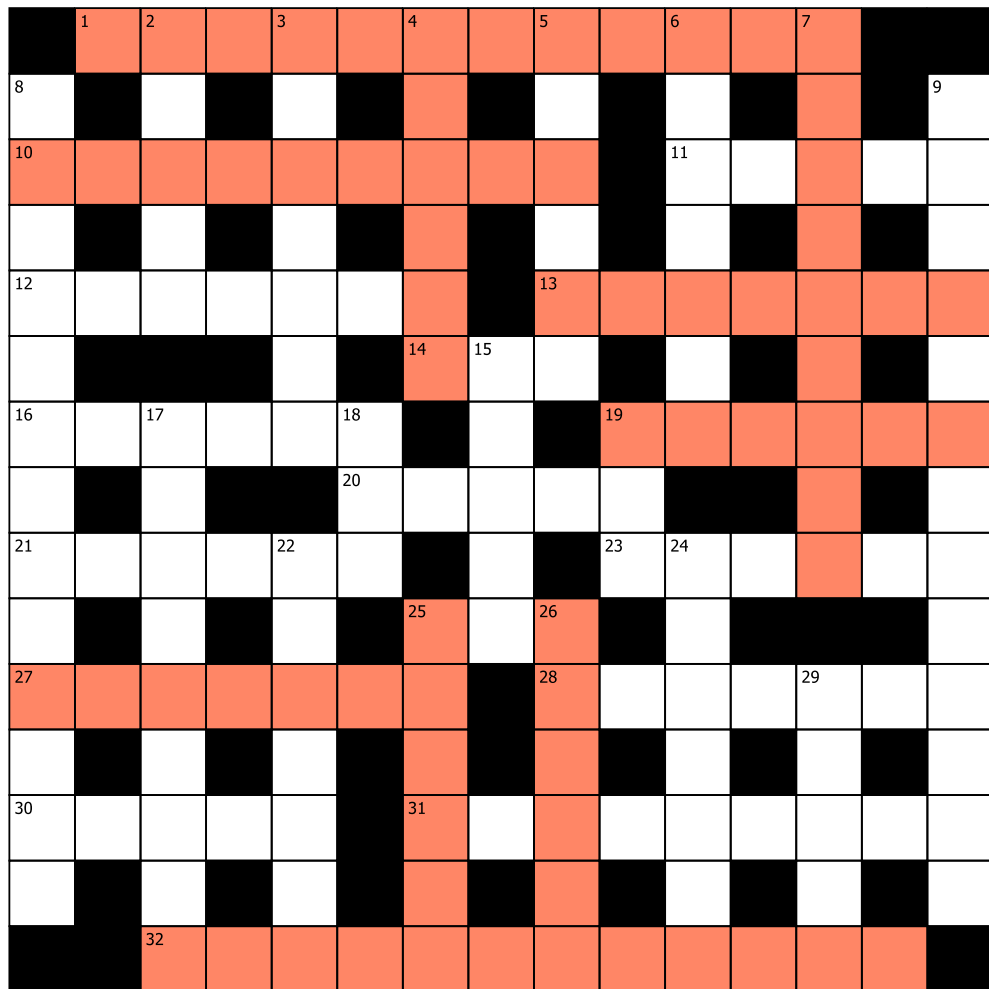

### Across

1. Halloween water game. [12]
10. Willem Dafoe stars in this remake of the 1922 german classic. [9]
11. Red and bloody, what a murderer leaves behind when dragging their victim. [5]
12. *Hotel Transylvania*, and *Frankenweenie*, for example. [7]
13. Items believed to confer protection upon its possessor. [7]
14. Personification of the sun. [3]
16. Shows that always reappear. [6]
19. The primary weapon of Shadowhunters. [6]
20. People who put up their Halloween decorations on the 1st of October. [5]
21. What lecturers always say they're looking for in our essays. [6]
23. Something one gains from experience. [6]
27. Pentagrams, occult rituals and wickedness. [7]
28. A artistic depiction of motionless figures representing a scene from history. [7]
30. A list is made of these. [5]
31. How you feel after a good (horror) movie. [9]
32. Shelley's monster. [12]

### Down

2. Someone who pretends. [5]
3. What you'll need after a long night of trick-or-treating. [3 4]
4. Zombies' favourite cuisine. [6]
5. 2017 movie where a savage murderer is on the prowl in Japan. [6]
6. Deliberately putting yourself in a situation where you are unwelcome. [7]
7. Where everyone ends up eventually. [9]
8. A 19th century ghost wearing a hoodie and listening to music on a phone, for example. [13]
9. Not believing that Halloween is the best time of the year. [13]
15. To be superior. [5]
17. Often enjoyed with gravy, Yorkshire pudding, carrots and potatoes. [9]
18. I spy. [3]
19. I spied. [3]
22. Card game of the rummy family. [7]
24. Existing as an original part of something. [7]
25. More than a screech but less than a scream. [6]
26. Haunted mansion in Warwick open to ghost hunts. [2 4]
29. The indigo one in *Inside out 2*. [5]

### Across

4. Particular tale has holy one surrender and become a concept. [6]
7. I bear small, disturbing cause of aggression. [6]
9. Impaled like a pumpkin by the sound of it. [5]
10. Familiar laugh almost building within old woman. [5 3]
11. Lying around like French girls - look at their tops! [6]
12. Description of flesh causes editor to cling to girl who's lost her head. [5]
14. Spew out lava and disintegrate innocent with temperature. [5]
20. Pull leg and back of neck to cut short and snatch. [6]
22. Ten more shuffling about, having same way to

get rid of them. [8]

23. Rose from the earth... brought back sense packing shivers... [5]
24. Particular place and time gives birth to plague bearer. [6]
25. This place seems yearning to start blasphemy. [6]

### Down

1. Carrying strange instrument in bark is barbarism. [7]
2. Victim of taking tube mid-stinger. [8]
3. Slicer chopped up whatever's left. [6]
4. You grow fat, collapsing in struggle. [3 2 3]
5. One might cry, this snake ruefully consumed it feet-first. [6]
6. Dread drowning - oddly, not over! Need some gas...

[5]

8. Dissect sorrowful expression. [3 2]
13. As of now, revenant devours separated people gathered for sweet treats. [3 5]
15. Unnerve slasher who had mutt's innards. [5 3]
16. Toll for elk to go astray in and around base. [5]
17. Long frenzy within outcasts. [7]
18. Bring back returning evil - it's after the group! [6]
19. The type of lady that makes things hard over-eats without even sampling starters. [6]
21. Steep climbing, short distance - sad there's no length. [5]



## CRYPTIC CROSSWORD

Submitted by David Latimer

(5 pts.)

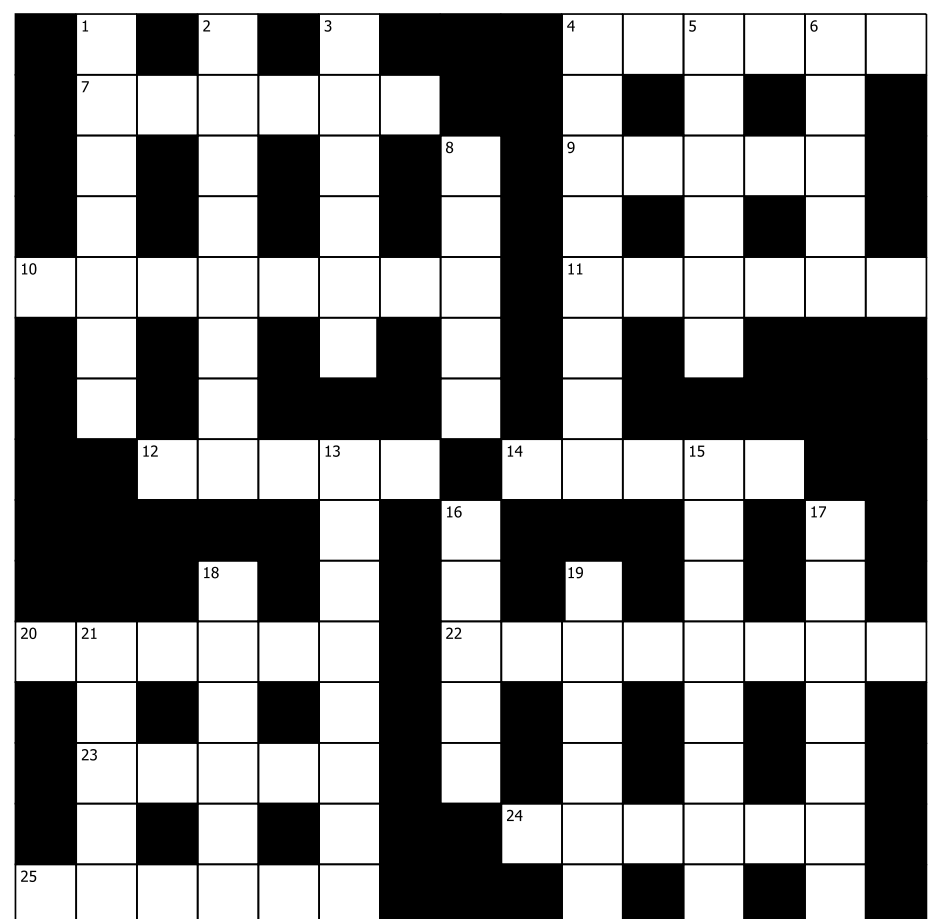

# MAZE (2 pts.)

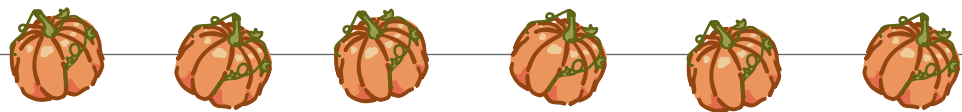
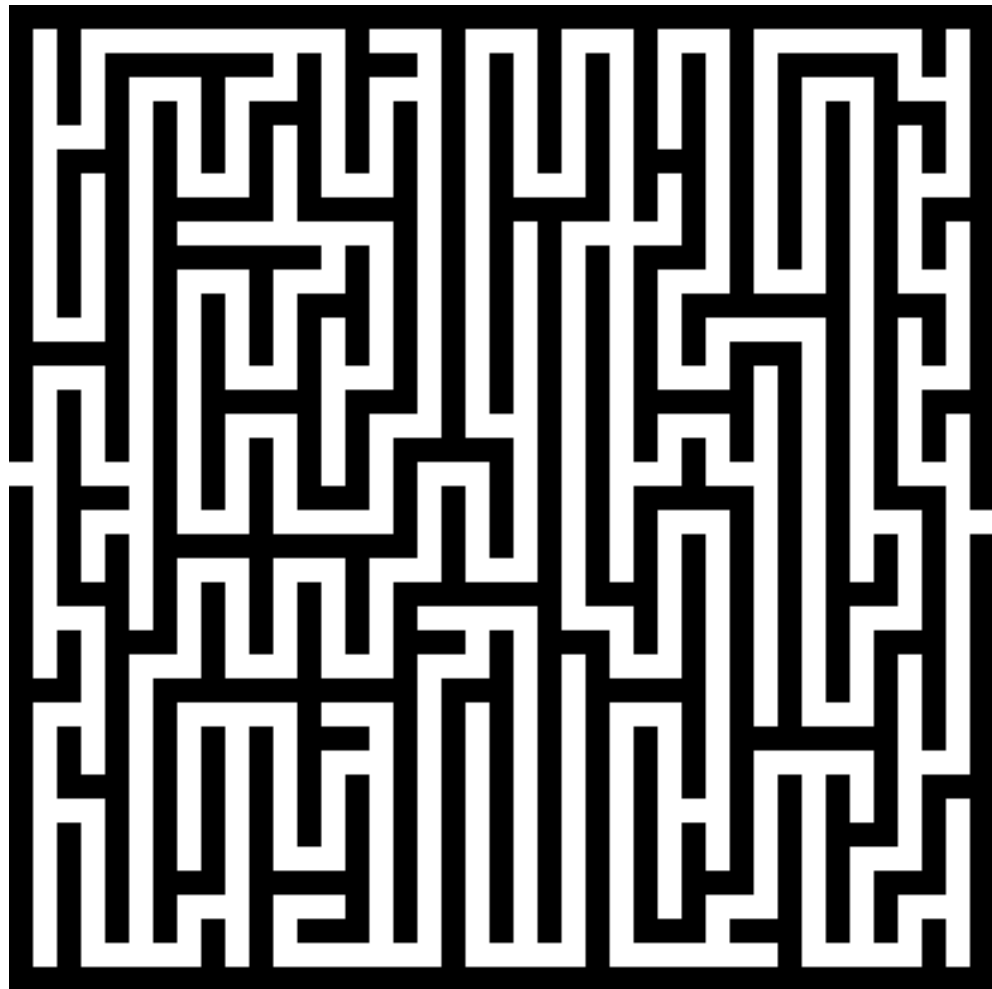

# COBWEBS (4 pts.)

Submitted by Shevitha Segar

### How-to:

Find the hidden themed words! Theme words fill the board entirely. No theme words overlap. Once all the theme words have been found, all the letters will have been used.

Hint: "Trick or Treat"

L	F	W	I	K	M	R	N
A	U	R	A	U	P	S	U
C	A	I	K	N	P	L	E
R	E	N	E	E	N	H	U
G	D	L	T	S	D	C	O
R	O	Y	S	I	T	E	H
A	G	T	W	I	T	N	G

# FELIX QUIZ TREE (15 pts.)

### Round 1 - Guess the Character

1. This otherworldly entity transcends our laws of physics. Appearing as a werewolf, a leper, a mummy, an old woman and a giant statue, red balloons are its calling card. [1 point]

### Round 2 - Guess the Movie

2. Florence Pugh, Horror, Sweden, "That's cultural, you know? We stick our elders in nursing homes. I'm sure they find that disturbing." [1 point]
3. Johnny Depp, Horror, Ohio, "Whatever you do... don't fall asleep" [1 point]
4. LaKeith Stanfield, Horror, Alabama, "The mind is a terrible things to waste" [1 point]
5. Violet McGraw, Horror, Georgia, "I was right here! I was screaming and shouting and none of you could see me. Why couldn't you see me?" [1 point]

### Round 3 - General Knowledge

6. **Calendar foods**  
If we eat Fish on St David's Day, Crab on US Independence Day and Goat on Christmas Day, what do we eat on Halloween? [2 points]
7. **Concealed animal**  
Here is a list of animals. But which other animal is hiding?  
RACCOON, PARROT, LEMMING, KOOKABURRA, AARDVARK, LINNET, OTTER? [3 points]
8. **One way or another?**  
Solve these one-dimensional anagrams: Salty Sherry, Rain on Hall, A Lazy Mink, I Insult Solomon.? [4 Points]
9. **How many people?**  
If 1 person can be considered LONELY, but 2 people are a NETWORK, how many do you need for them to become THREATENING? [1 Point]



# BRIDGES (5 pts.)

### How-to:

Bridges consists of number islands on a grid. Your aim is to connect all islands according to the number of bridges for that island. There are no more than two bridges in the same direction. Bridges can only be vertical or horizontal and are not allowed to cross islands or other bridges. When completed, one should be able to move from any island to another across the bridges.

	1			2		2
2			2		3	
		1				2
			4		5	
3		3				3
					1	
	1		4			3

# SUDOKU

	3	7		8	2			
					9	2		
9				6			3	7
8		4	7				5	
		1				6		4
	9				8	3		
4		3		2				
	8	9				1		
	2					4	9	3

	1			6	9			
5				1			7	
	7		3	5			8	
3							2	8
1					9	5		
				8				
		4		2				
2							3	
	9		7	1				4

8			7					
				1			2	
				8		3		
6		9				2	7	
3		7		4				5
		4						
	1	3	9					
2							6	
9		6	2				1	

	4	8						
5	2		1	3		4		9
1				6			5	
		6			2			8
			3	8		6	7	
					6			
			2	5		7	9	6
3				4				
		5		9			3	4

							9	
					5		2	
	5	7		4	6			
	9				1	5	3	
					2	6		
4			9	3				
		4			9			8
	1							2
			8				7	

4							1		
				1	9			7	
9				2	5	6	4		
			7						
		7					3	5	4
3				5					
5		6		9					
	9			3		1	6		
2	8								9

Medium (1 pt. each)

Hard (2 pts. each)

Extra hard (3 pts. each)

# GROUPING GRIDS

Submitted by William West & Vittoria Dessi

Ball	Blank	Note	Pep
Shun	Spirit	Neglect	Slight
Fit	March	Bird	Shade
Camera	Ghost	Guts	Spunk

Medium (3 pts.)

### How-to:

For fans of *Only Connect*! The sixteen clues in each of these puzzles can be placed into four groups of four, each with a connecting feature. To solve the puzzle, write these groups and their connections below! An example can be seen in last week's solutions.

Skeleton	Bemuse	Bat	Umpire
Stun	Old	Five	Spider
Zombie	Fox	Devil	Ice
Pumpkin	Bail	Confound	Stump

Hard (4 pts.)

				Connections
1.				
2.				
3.				
4.				

				Connections
1.				
2.				
3.				
4.				



# COMIC

Submitted by Tengyu Zhao



## Nonogram Solution

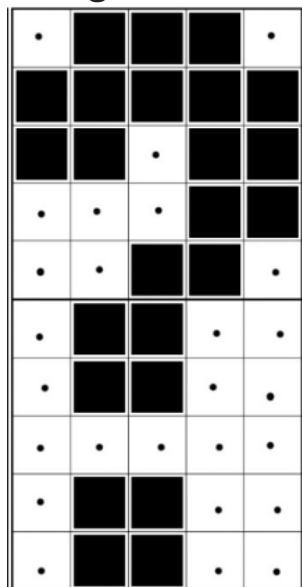

## Quiz Tree Solutions

1. James Bond
2. Seven
3. Whiplash
4. The Imitation Game
5. The Pursuit of Happyness
6. Penguins
- 7a. Cent, b. Kent, c. Lent, d. Tent, Linked by the word ENT and Ents were created by J.R.R. Tolkien in The Lord of the Rings.
8. Budapest. The capitals of European countries alphabetically.

## Puzzle Editor's Note

Dearest Puzzlers,

Boo! In case you hadn't already noticed, welcome to our Halloween Special. We've got an exquisite selection of creepy conundrums to keep you occupied this week, featuring Halloween-themed crosswords, connections, cobwebs, and quizzes!

It's been a tumultuous week for our leaderboard! The Menu has surged ahead as the first team to break 100 points, boosted by last week's extra puzzles. Team GuineaPig now holds second place, with the rest still catching up. But with this spook-tacular puzzles issue, there's plenty of opportunity to earn those all-important points!

Finally, I'd like to thank everyone who has contributed to the puzzles section: David Latimer for the Cryptic Crossword, William and Vittoria for the Connections, Shevitha Segar for the Cobwebs and Tengyu for the Comic.

That leaves me with nothing more to say, other than have a fantastic week of crossing, connecting, completing, code-cracking, comic-consuming, maze-running, quizzing, word-finding, bridge-building and competing!

- Ivin



## Previous Puzzles' solutions



Regular



Cryptic

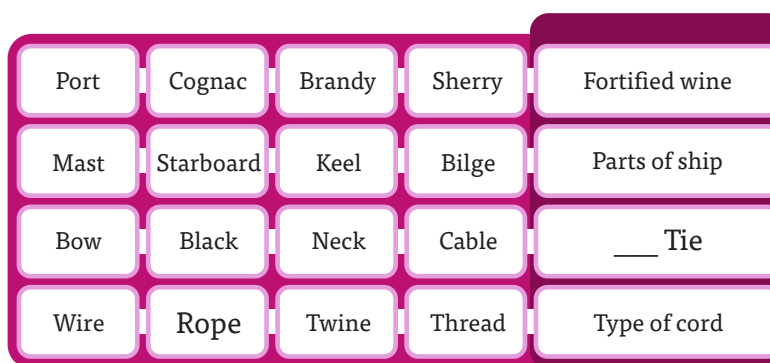

Medium grouping grid

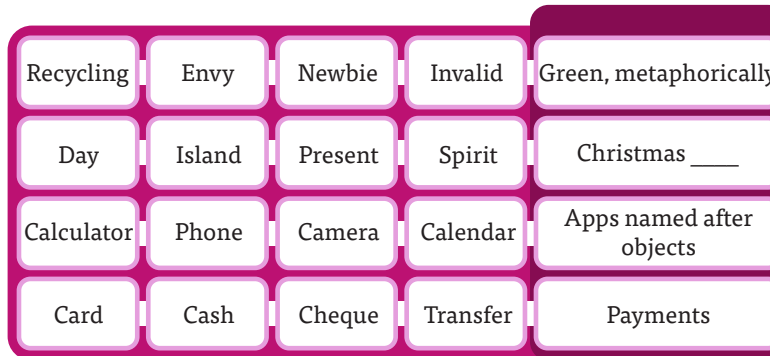

Hard grouping grid

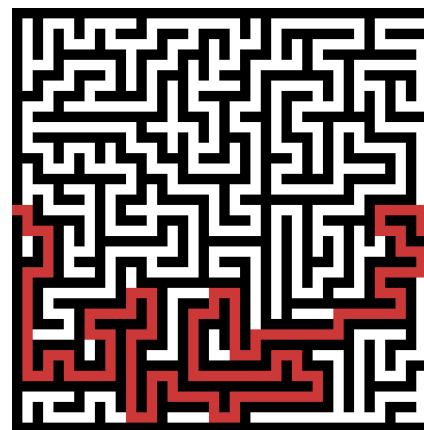

Maze

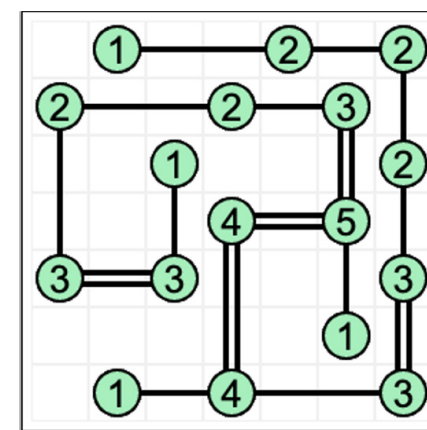

Bridges

"You But books – they're different. When you watch a film, you're sort of can outsider looking in. With a book you're right there. You aer inside. You are the main character."

Anagram: Ariel Otis = Solitaire

Quote from: Solitaire by Alice Oseman

Cryptogram

## SPORT

# The Imperial Immortals American Football Club

David Bates, President of Imperial's American Football Club, Imperial Immortals, shares the thrill and strategy behind American football.

## Imperial Immortals President DAVID BATES

Our American football is very different to most other sports. The main difference is that the match is broken up into roughly 60 plays, with short breaks in between, which adds to the sport's intensity. The gameplay in American football also quite complicated and should not be underestimated.

It's all about gaining distance, short and often; you have to move forwards 10 yards within four plays and then, if successful, you get another four plays to make another 10 yards. You keep going until you either get the ball in the opponents' end zone and score a touchdown or, if you are unsuccessful, the other team takes over possession and they repeat the process, with the goal of

getting to your endzone.

It's a very technical sport heavily tied to many strategies, but that's something we can teach most members who have never played before. I like to describe it as a game of chess - with real people as the pieces - making it the perfect sport for an Imperial student! We have both an offensive and defensive playbook which has all our strategies in. We learn them during "Chalk Talk" classroom sessions on Thursdays and implement them at training on Tuesdays (at Harlington) and Saturdays (at Lillie Rec) so that everyone is on the same page on gameday. Chalk Talk sessions are crucial, especially for quarterbacks, as they teach the quarterback exactly where each receiver will be running. This preparation allows for more precise throws to receivers, increasing the chances of a successful play.

Our social secretary, Angelos Angelidis, who has been a big driver in recruiting, adds: "This year we're doing more socials and we're doing them bigger.



**American football is not just a game; it's a beautifully intense and strategic sport that's growing rapidly in popularity.**

We're also partnering up with our sister society, Imperial Titans Cheerleading, more this year; Joint family mentoring scheme, Thorpe Park trips and, of course, our formal dinners are all in our plan. We attend every sports night, have regular

Unlimited Wings socials all over London, and plan fun activities such as mini golf, bowling and more throughout the year. Of course, we also host regular watch parties at bars all over London to watch some good old football on Sundays."

Sadly, there's a large amount of misinformation about the game - which is a shame as it's such a beautifully intense and intellectual sport. I always tell people there's a reason it's the most popular sport in America - it's only a matter of time before it's one of the most popular sports globally, especially with its introduction to the 2028 Olympics.

It has been a key focus of the committee, since the start of fresher's week, to show the university and onboarding freshers that, among all the typical European sports practiced at Imperial, we exist, and to try and challenge people's perceptions of the sport. Based on our recruitment, I think we have achieved this. If you want to try out one of the fastest growing sports in the UK, send us a message on Instagram @ImmortalsAFC.

### Upcoming events:

#### 10th November

Home game against City in Harlington (the start of our regular season and pursuit for promotion).

#### 9th February

Union's Sunday Super Bowl viewing, one of the best Union nights of the year and one not to miss for both avid fans and strangers to the sport, so keep an eye out for tickets closer to the time.



Imperial Immortals 23/24 Team David Bates

# Billionaire backed boys boycott Ballon D'or

Lila explains the recent Los Merengues' controversial Eton mess.

**Sport Writer**

**LILA HARRISON**

On Monday evening, the richest, most successful, and largest club in football history, Real Madrid, boycotted one of the sport's biggest nights – the Ballon D'Or award show.

Awarded annually by France Football since 1956, the Ballon D'or, or also called the Golden Ball, recognises the world's best football player based on votes from international journalists. With a trophy of a golden football, the ceremony has evolved into the emblem of individual brilliance in the team sport of football, determining the best player of that year outright.

Historically dominated by legends Lionel Messi (8 wins) and Cristiano Ronaldo (5 wins), the award signifies not only personal achievement but also a player's influence on the game and their wider character and ethic – a hot topic in the realm of exceedingly large contracts and disputable player characters.

Perhaps the fact that Real Madrid holds a record 36 La Liga titles and stupendous 15 Champions League trophies was not enough for the old previously government-funded club. All year, fans expected that one Real Madrid player would take home the title – be it Jude Bellingham, Kylian Mbappe, or Vinicius Jr – only to be disappointed, despite the major recent speculations. Instead, it was the Spanish midfielder Rodrigo, who had won the Premier League, UEFA Super Cup, UEFA Club World Cup, and the European Championship with

Manchester City in the previous season.

I admit, I am not a Manchester City fanatical. One may even say I hold a particular dislike for them. However, there is no denying that Rodrigo, known as Rodri, is the best holding midfielder in the world. He epitomises the ideal number 6, playing a pivotal role in Manchester City's Champions League triumph. He is what every club look for in a defensive midfielder

During the 2023-24 Premier League season, Manchester City remained unbeaten in every match Rodri played, achieving a remarkable record of 27 wins and 7 draws. In stark contrast, they managed just one win and suffered three losses in his absence. Furthermore, Spain enjoyed a perfect Euro 2024 campaign, winning all seven of their matches.

Needless to say, when Manchester City were informed Rodri was going to receive the 2024 Ballon D'Or award, they passed the message onto Real Madrid. We exist in a modern football world where a certain "There we go!" spoils all hype. Vinicius Jr would not be winning it.

What happened next? Absence. From the ceremony at which Real Madrid was awarded best club and best coach – Carlo Ancelotti won over Xabi Alonso, Leverkusen's coach who went unbeaten for a domestic double – followed outrage. Left, right, and centre, Madrid and Brazil players rushed to social media to insist this travesty. Surprisingly, Carlo Ancelotti even thanked Vinicius in his own post. Kylian Mbappe and Jude Bellingham who placed 6th and 3rd respectively, did not comment, supposedly due to "social media problems." It seems the

two of them experienced basic human embarrassment.

Vinicius Jr is a brilliant player. At 24, he is one of the best wingers in the world. Any team would be itching to have him after his iconic performances last season. But he only scored 35 goals. The ever-mocked Darwin Nunez scored 31. Mo Salah? 39. Cole Palmer? 42. Rodri scored 21 – impressive for a defensive player.

For an award given for individual brilliance, it is arrogant, and frankly embarrassing, to expect an award

because of the club you are in and the trophies you have won. The standard is perhaps not what it used to be with the likes of Messi and Ronaldo, but Rodri is the rightful winner of this year's award.

A following 4-0 loss against FC Barcelona in the El Clasico match and Lamine Yamal (FC Barcelona) winning the Golden Boy at the ceremony, did anything but help Real Madrid's spirit. Soon after, fans left hate messages on unrelated Filipino-American songwriter Olivia Rodrigo's Instagram.



Rodri (top) took home the Ballon D'Or award this year, and Vinicius Jr (bottom left) and Jude Bellingham (bottom right) placed 2nd and 3rd in the standings respectively. Wikimedia Commons

